



ADV160

Owner's Manual Manual Pemilik

Read before you ride!
Baca sebelum menunggang!



Use Honda
Genuine Parts

This manual should be considered a permanent part of the vehicle and should remain with the vehicle when it is resold.

This publication includes the latest production information available before printing. Honda Motor Co., Ltd. reserves the right to make changes at any time without notice and without incurring any obligation.

No part of this publication may be reproduced without written permission.

The vehicle pictured in this owner's manual may not match your actual vehicle.

Welcome

Congratulations on your purchase of a new Honda vehicle. Your selection of a Honda makes you part of a worldwide family of satisfied customers who appreciate Honda's reputation for building quality into every product.

To ensure your safety and riding pleasure:

- Read this owner's manual carefully.
- Follow all recommendations and procedures contained in this manual.
- Pay close attention to safety messages contained in this manual and on the vehicle.
- The following codes in this manual indicate the destination.

- The illustrations here in are based on the ADV160A III MA type type.

Destination Codes

Code	Destination
------	-------------

ADV160A

MA	Malaysia
----	----------

III MA	Malaysia
--------	----------

VII MA	Malaysia
--------	----------

A Few Words About Safety

Your safety, and the safety of others, is very important. Operating this vehicle safely is an important responsibility.

To help you make informed decisions about safety, we have provided operating procedures and other information on safety labels and in this manual. This information alerts you to potential hazards that could hurt you or others.

Of course, it is not practical or possible to warn you about all hazards associated with operating or maintaining a vehicle. You must use your own good judgement.

You will find important safety information in a variety of forms, including:

- Safety labels on the vehicle.
- Safety Messages preceded by a safety alert symbol  and one of three signal words: DANGER, WARNING, or CAUTION.

These signal words mean:

DANGER

You **WILL** be **KILLED** or **SERIOUSLY HURT** if you don't follow instructions.

WARNING

You **CAN** be **KILLED** or **SERIOUSLY HURT** if you don't follow instructions.

CAUTION

You **CAN** be **HURT** if you don't follow instructions.

Other important information is provided under the following title:

NOTICE

Information to help you avoid damage to your vehicle, other property, or the environment.

Contents

Vehicle Safety P. 2

Operation Guide P. 20

Maintenance P. 137

Troubleshooting P. 167

Information P. 193

Specifications P. 208

Vehicle Safety

This section contains important information for safe riding of your vehicle.
Please read this section carefully.

Safety Guidelines	P. 3
Image Labels	P. 7
Safety Precautions	P. 11
Riding Precautions	P. 13
Accessories & Modifications	P. 18
Loading	P. 19

Safety Guidelines

Follow these guidelines to enhance your safety:

- Perform all routine and regular inspections specified in this manual.
- Stop the engine and keep sparks and flames away before filling the fuel tank.
- Do not run the engine in enclosed or partly enclosed areas. Carbon monoxide in exhaust gases is toxic and can kill you.

Always Wear a Helmet

It's a proven fact: helmets and protective apparel significantly reduce the number and severity of head and other injuries. Always wear an approved helmet and protective apparel.

➔ P. 11

Before Riding

Make sure that you are physically fit, mentally focused, and free of alcohol and drugs. Check that you and your passenger are both wearing an approved helmet and protective apparel. Instruct your passenger on holding onto the rear grips or your waist, leaning with you in turns, and keeping their feet on the footpegs, even when the vehicle is stopped.

Take Time to Learn & Practice

Even if you have ridden other vehicles, practice riding in a safe area to become familiar with how this vehicle works and handles, and to become accustomed to the vehicle's size and weight.

Ride Defensively

Always pay attention to other vehicles around you, and do not assume that other drivers see you. Be prepared to stop quickly or perform an evasive maneuver.

Make Yourself Easy to See

Make yourself more visible, especially at night, by wearing bright reflective clothing, positioning yourself so other drivers can see you, signaling before turning or changing lanes, and using your horn when necessary.

Ride within Your Limits

Never ride beyond your personal abilities or faster than conditions warrant. Fatigue and inattention can impair your ability to use good judgement and ride safely.

Don't Drink or Use Drugs and Ride

Alcohol or drugs and riding don't mix. Even one alcoholic drink can reduce your ability to respond to changing conditions, and your reaction time gets worse with every additional drink. The same is true for drug use. Don't drink or use and ride, and don't let your friends do it either.

Keep Your Honda in Safe Condition

It's important to keep your vehicle properly maintained and in safe riding condition. Inspect your vehicle before every ride and perform all recommended maintenance. Never exceed load limits (➤ P. 19), and do not modify your vehicle or install accessories that would make your vehicle unsafe (➤ P. 18).

If You are Involved in a Crash

Personal safety is your first priority. If you or anyone else has been injured, take time to assess the severity of the injuries and whether it is safe to continue riding. Call for emergency assistance if needed. Also follow applicable laws and regulations if another person or vehicle is involved in the crash.

If you decide to continue riding, first turn the ignition switch to the **O** (Off) position, and evaluate the condition of your vehicle. Inspect for fluid leaks, check the tightness of critical nuts and bolts, and check the handlebar, control levers, brakes, and wheels. Ride slowly and cautiously.

Your vehicle may have suffered damage that is not immediately apparent. Have your vehicle thoroughly checked at a qualified service facility as soon as possible.

Carbon Monoxide Hazard

Exhaust contains poisonous carbon monoxide, a colourless, odorless gas. Breathing carbon monoxide can cause loss of consciousness and may lead to death.

If you run the engine in a confined or even partly enclosed area, the air you breathe could contain a dangerous amount of carbon monoxide.

Never run your vehicle inside a garage or other enclosure.

WARNING

Running the engine of your vehicle while in an enclosed or even partially enclosed area can cause a rapid build-up of toxic carbon monoxide gas.

Breathing this colourless, odorless gas can quickly cause unconsciousness and lead to death.

Only run your vehicle's engine when it is located in a well ventilated area outdoors.

Image Labels

The following pages describe the label meanings. Some labels warn you of potential hazards that could cause serious injury. Others provide important safety information. Read this information carefully and don't remove the labels.

If a label comes off or becomes hard to read, contact your dealer for a replacement.

There is a specific symbol on each label. The meanings of each symbol and label are as follows.



Read instructions contained in Owner's Manual carefully.



Read instructions contained in Shop Manual carefully. In the interest of safety, take the vehicle to be serviced only by your dealer.



DANGER (with RED background)

You **WILL** be **KILLED** or **SERIOUSLY HURT** if you don't follow instructions.

WARNING (with ORANGE background)

You **CAN** be **KILLED** or **SERIOUSLY HURT** if you don't follow instructions.

CAUTION (with YELLOW background)

You **CAN** be **HURT** if you don't follow instructions.

sample



BATTERY LABEL DANGER

- Keep flame and spark away from the battery. Battery produce explosive gas that can cause explosion.
- Wear the eye protection and rubber gloves when handling the battery, or you can get burned or lose your eyesight by the battery electrolyte.
- Do not allow children and other people to touch a battery unless they understand proper handling and hazards of the battery very well.
- Handle the battery electrolyte with extreme care as it contains dilute sulfuric acid. Contact with your skin or eyes can burn you or cause loss of your eyesight.
- Read this manual carefully and understand it before handling the battery. Neglect of the instructions can cause personal injury and damage to the vehicle.
- Do not use a battery with the electrolyte at or below the lower level mark. It can explode causing serious injury.
- Do not knock down the battery.
- Do not put in short the terminals of the battery.



RADIATOR CAP LABEL
DANGER

NEVER OPEN WHEN HOT.
Hot coolant will scald you.
Relief pressure valve begins to open at **108 kPa**.



ABS INFORMATION LABEL

This model equipped with an Anti-lock Brake System (ABS) on front wheel.

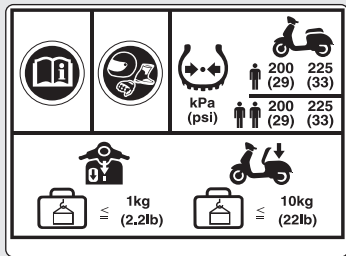

TYRE INFORMATION & CARGO LIMIT LABEL

For your protection, always wear helmet, protective apparel.

Cold tyre pressure:

[Driver only]

Front **200 kPa (2.00 kgf/cm², 29 psi)**

Rear **225 kPa (2.25 kgf/cm², 33 psi)**

[Driver and passenger]

Front **200 kPa (2.00 kgf/cm², 29 psi)**

Rear **225 kPa (2.25 kgf/cm², 33 psi)**

Cargo limit:

Front box **1 kg (2.2 lb)**

Centre compartment **10 kg (22 lb)**

Safety Precautions

- Ride cautiously and keep your hands on the handlebar and feet on the floor.
- Instruct your passenger to keep their hands on the rear grips or your waist and their feet on the footpegs while riding.
- Always consider the safety of your passenger, as well as other drivers and riders.

Protective Apparel

Make sure that you and any passenger are wearing an approved helmet, eye protection, and high-visibility protective clothing. Avoid wearing loose clothes that could get caught on any part of the vehicle. Ride defensively in response to weather and road conditions.

■ Helmet

Should be safety-standard certified, high-visibility, and the correct size for your head.

- Must fit comfortably but securely, with the chin strap fastened.
- Face shield with unobstructed field of vision or other approved eye protection.

⚠️ WARNING

Not wearing a helmet increases the chance of serious injury or death in a crash.

Make sure that you and any passenger always wear an approved helmet and protective apparel.

Safety Precautions

| Gloves

Full-finger leather gloves with high abrasion resistance.

| Boots or Riding Shoes

Sturdy boots with non-slip soles and ankle protection.

| Jacket and Trousers

Protective, highly visible, long-sleeved jacket and durable trousers for riding (or a protective suit).

Riding Precautions

Running-in Period

During the first 500 km (300 miles) of running, follow these guidelines to ensure your vehicle's future reliability and performance.

- Avoid full-throttle starts and rapid acceleration.
- Avoid hard braking.
- Ride conservatively.

Brakes

Observe the following guidelines:

- Avoid excessively hard braking.
 - ▶ Sudden braking can reduce the vehicle's stability.
 - ▶ Where possible, reduce speed before turning; otherwise, you risk sliding out.
- Exercise caution on low traction surfaces.
 - ▶ The tyres slip more easily on such surfaces and braking distances are longer.
- Avoid continuous braking.
 - ▶ Repeated braking, such as when descending long, steep slopes can seriously overheat the brakes, reducing their effectiveness.
- For full braking effectiveness, operate both the front and rear brakes together.

■ Anti-lock Brake System (ABS) on Front Wheel

This model equipped with an Anti-lock Brake System (ABS) designed to help prevent the front brake from locking up during hard braking.

- There is no ABS function to the rear wheel.
- ABS does not reduce braking distance. In certain circumstances, ABS may result in a longer stopping distance.
- ABS does not function at speeds below 10 km/h (6 mph).
- The front brake lever may recoil slightly when applying the brakes. This is normal.
- Always use the recommended front/rear tyres to ensure correct ABS operation.

■ Wet or Rainy Conditions

Road surfaces are slippery when wet, and wet brakes further reduce braking efficiency. Exercise extra caution when braking in wet conditions.

If the brakes get wet, apply the brakes while riding at low speed to help them dry.

Parking

- Park on a firm, level surface.
- If you must park on a slight incline or loose surface, park so that the vehicle cannot move or fall over.
- Make sure that high-temperature parts cannot come into contact with flammable materials.
- Do not touch the engine, muffler, brakes, and other high-temperature parts until they cool down.
- To reduce the likelihood of theft, always lock the handlebar, lock the ignition switch (🔒 P. 95) and leave your vehicle while taking the Honda SMART Key with you. Deactivate the Honda SMART Key system if necessary. 🔑 P. 90
Use of an anti-theft device is also recommended.
Also set the anti-theft alarm system.

■ Parking with the Side Stand or Centre Stand

1. Stop the engine.
2. **Using the side stand**
Push the side stand down.
Slowly lean the vehicle to the left until its weight rests on the side stand.
Turn the handlebar fully to the left.
 - ▶ Turning the handlebar to the right reduces stability and may cause the vehicle to fall.

Using the centre stand

To lower the centre stand, stand on the left side of the vehicle.
Hold the left handle grip and the rear grip.
Press down on the tip of the centre stand with your right foot and, simultaneously, pull up and back.

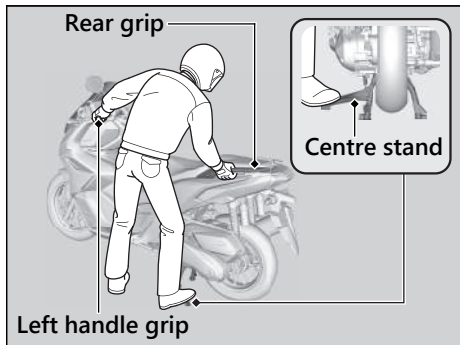

3. Turn the ignition switch to the  (Lock) position (➤ P. 88) and lock the ignition switch (➤ P. 95).
4. Set the anti-theft alarm system. ➤ P. 98

Refuelling and Fuel Guidelines

Follow these guidelines to protect the engine, fuel system, and catalytic converter:

- Use only unleaded petrol.
- Use the recommended octane number. Using lower octane petrol will result in decreased engine performance.
- Do not use fuels containing a high concentration of alcohol. ➤ P. 206
- Do not use stale or contaminated petrol or an oil/petrol mixture.
- Avoid getting dirt or water in the fuel tank.

Honda Selectable Torque Control

When the Honda Selectable Torque Control (Torque Control) detects rear wheel spin during acceleration, the system will limit the amount of torque applied to the rear wheel.

Torque Control does not work during deceleration and will not prevent the rear wheel from skidding due to engine braking. Do not close the throttle suddenly, especially when riding on slippery surfaces.

Torque Control may not compensate for rough road conditions or rapid throttle operation. Always consider road and weather conditions, as well as your skills and condition, when applying throttle.

If your vehicle gets stuck in mud, snow, or sand, it may be easier to free it by turning off the Torque Control temporarily.

Temporarily turning off Torque Control also may help you maintain control and balance when riding on off-road terrain.

Always use the recommended tyres and the Honda Genuine Parts for drive system such as the drive belt and weight rollers, to ensure correct Torque Control operation.

Accessories & Modifications

We strongly advise that you do not add any accessories that were not specifically designed for your vehicle by Honda or make modifications to your vehicle from its original design. Doing so can make it unsafe. Modifying your vehicle may also void your warranty and make your vehicle illegal to operate on public roads. Before deciding to install accessories on your vehicle, be certain the modification is safe and legal.

WARNING

Improper accessories or modifications can cause a crash in which you can be seriously hurt or killed.

Follow all instructions in this owner's manual regarding accessories and modifications.

Do not pull a trailer with, or attach a sidecar to, your vehicle. Your vehicle was not designed for these attachments, and their use can seriously impair your vehicle's handling.

Loading

- Carrying extra weight affects your vehicle's handling, braking, and stability. Always ride at a safe speed for the load you are carrying.
- Avoid carrying an excessive load and keep within specified load limits.
Maximum weight capacity / Maximum luggage weight 📖 P. 208
- Tie all luggage securely, evenly balanced, and close to the centre of the vehicle.
- Do not place objects near the lights or the muffler.

WARNING

Overloading or improper loading can cause a crash and you can be seriously hurt or killed.

Follow all load limits and other loading guidelines in this manual.

Parts Location

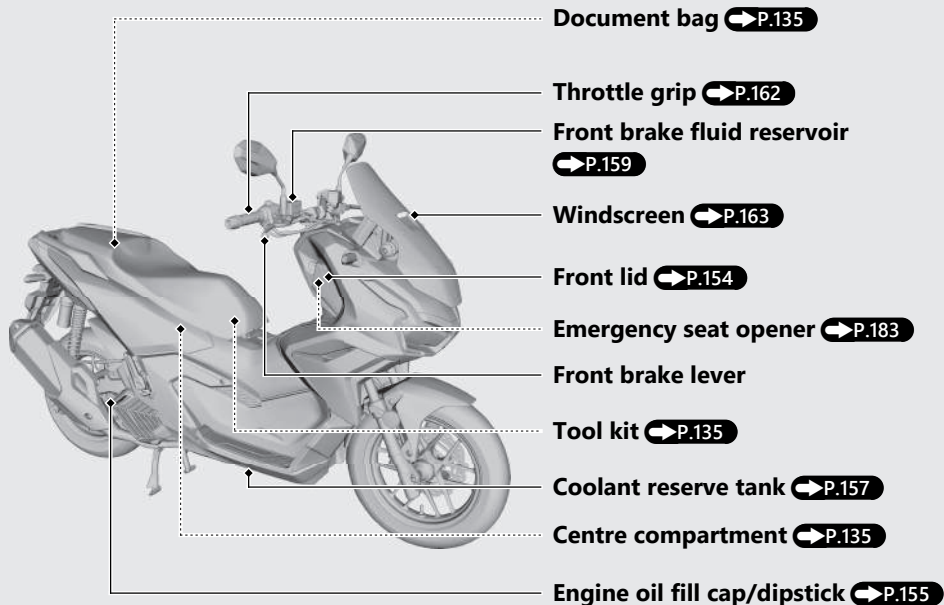

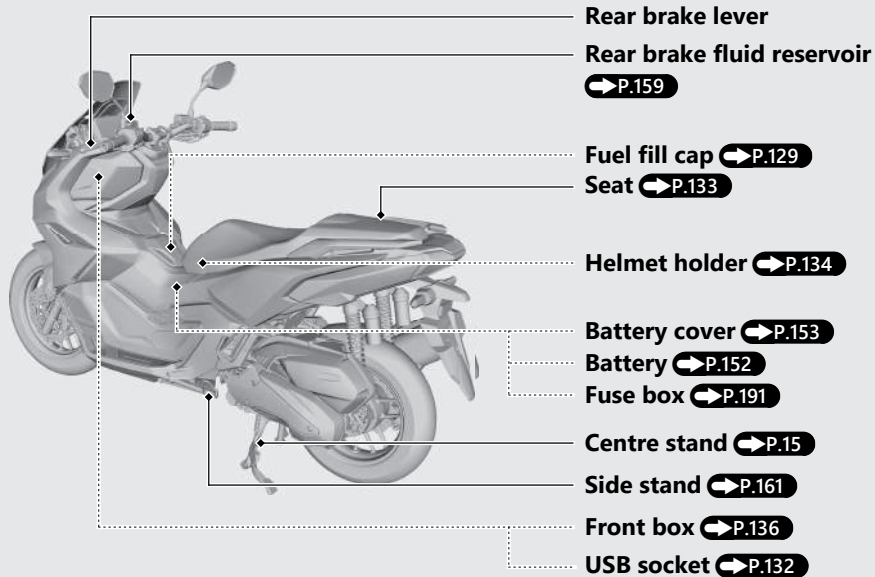

Instruments

III MA, VII MA type





Do not operate the display functions for a long time with the engine stopped. It may result in a low (or dead) battery.

Speedometer/Tachometer area  P.27

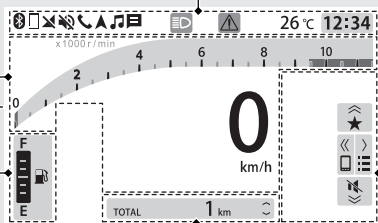
Status bar  P.25



Fuel gauge  P.28

INFO area  P.29 /
Pop-up information  P.59

Selectable area  P.35

Instruments *(Continued)*

The meter has three display types.

The display and arrangement change depending on each display type.

Initial setting is BAR.

▶ Tachometer is available when display type is BAR or CIRCLE.

To change the display type: ➡ P.45

Display type: CIRCLE

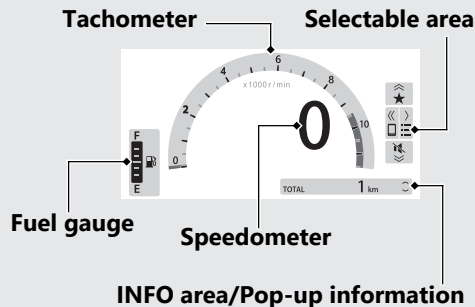

Display type: SIMPLE

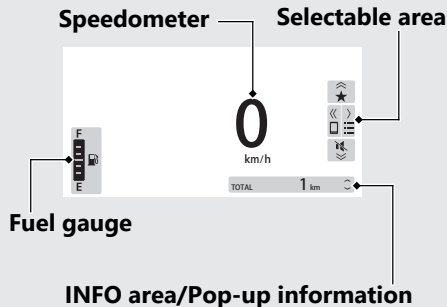

Status bar



Status icons

Display the Honda RoadSync status.

➔ P.111

High beam indicator

Warning indicator

Comes on when your vehicle has warning information.

Also it is displayed as pop-up information in the INFO area. ➔ P.59

Instruments *(Continued)*



AIR TEMP meter

Displays the ambient temperature.

Display range: -5 °C to 40 °C

- Below -5 °C or above 40 °C : "---" flash

Road heat and exhaust from another vehicle can affect the temperature reading when your vehicle speed is less than 30 km/h (19 mph). It may take several minutes for the display to be updated after the temperature reading has stabilized.

Clock (12-hour or 24-hour display)

To set the clock: **P.50**

Speedometer/Tachometer area

Display type: BAR

Tachometer

Tachometer is available when display type is BAR or CIRCLE.

DISPLAY TYPE setting: ➔ P.45

NOTICE

Do not operate the engine in the tachometer red zone. Excessive engine speed can adversely affect engine life.

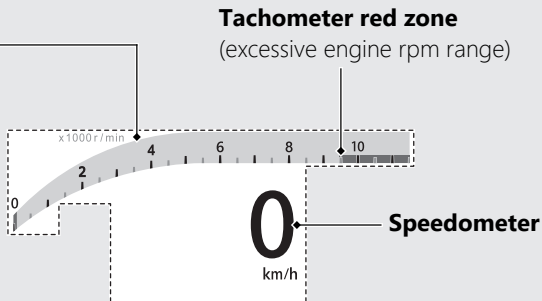

Instruments *(Continued)*

Fuel gauge



Remaining fuel when only 1st (E) segment starts flashing:
approximately 1.32 L (0.349 US gal, 0.290 Imp gal)

If the fuel gauge indicator flashes in a repeat pattern or turns off:  **P.175**

NOTICE

You should refuel when the reading approaches the 1st (E) segment. Running out of fuel can cause the engine to misfire, damaging the catalytic converter.



INFO area

Pressing the ▲ or ▼ of the ◀▶ sel switch switches between the information display selected in the FAVORITE INFO setting.

FAVORITE INFO setting: ➡ P.47

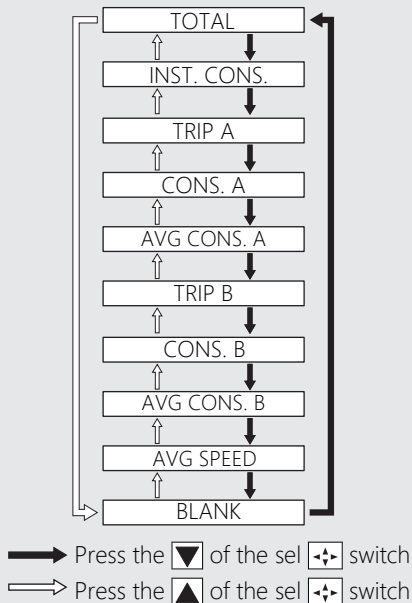

Instruments *(Continued)*

You can select from below items as display information.

If no item is selected, the INFO area is not displayed.

- Odometer [TOTAL]
- Current fuel mileage [INST. CONS.]
- Tripmeter A [TRIP A]
- Tripmeter A fuel consumption [CONS. A]
- Tripmeter A average fuel mileage [AVG CONS. A]
- Tripmeter B [TRIP B]
- Tripmeter B fuel consumption [CONS. B]
- Tripmeter B average fuel mileage [AVG CONS. B]
- Average speed [AVG SPEED]
- BLANK display

Odometer [TOTAL]

Total distance ridden.

TOTAL 1 km 

When "-----" is displayed, go to your dealer for service.

Current fuel mileage [INST. CONS.]

Displays the current instant fuel mileage.

Display range: 0 to 80 km/L
(0 to 8 L/100 km,
0 to 200 MPG,
or 0 to 50 mile/L)

- When your speed is less than 5 km/h (3 mph): zero segment is displayed.

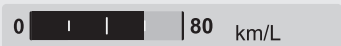
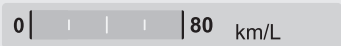
**Zero segment**

When it is not displayed properly except for the above-mentioned case, go to your dealer for service.

Instruments *(Continued)*

■ Tripmeter [TRIP A/B]

Distance ridden since tripmeter was reset.

TRIPA **125.0** km  

TRIPB **250.0** km  

When "----.-" is displayed, go to your dealer for service.

To reset the tripmeter:  **P.38**

■ Fuel consumption [CONS. A/B]

Displays the fuel consumption since the selected tripmeter was reset.

The fuel consumption will be calculated based on value of the tripmeter A or B.

Display range: 0.0 to 299.9 L (gal)

CONS.A **4.3** L  

CONS.B **11.4** L  

When "----.-" is displayed, go to your dealer for service.

To reset the fuel consumption:  **P.38**

Average fuel mileage [AVG CONS. A/B]

Displays the average fuel mileage since the selected tripmeter was reset.

The average fuel mileage will be calculated based on value of the tripmeter A or B.

AVG CONS. A **30** km/L  

AVG CONS. B **25** km/L  

Display range: 0.0 to 299.9 km/L (L/100 km, MPG, or mile/L)

- More than 299.9 km/L (MPG or mile/L): "299.9" is displayed.
- Above 299.9 L/100km : "--.-" is displayed.
- Less than 0.1 L/100km : "0.0" is displayed.
- When the tripmeter A or B is reset: "---.-" is displayed.

When "--.-" is displayed except for the above-mentioned cases, go to your dealer for service.

To reset the average fuel mileage:

 **P.38**



Instruments *(Continued)*

Average speed [AVG SPEED]

Displays the average speed since when the engine starts.

Display range: 0 to 299 km/h (0 to 186 mph)

- Initial display: "---" is displayed.
- When your vehicle has traveled less than 0.2 km (0.12 mile) since the engine was started: "---" is displayed.
- When your vehicle operating time is less than about 15 seconds since the engine was started: "---" is displayed.

AVG SPEED **34** km/h  



When "---" is displayed except for the above-mentioned cases, go to your dealer for service.

BLANK display

Displays the blank.

Selectable area

You can select the following:

- FAVORITE SWITCH  P.36
- General menu  P.36
- Honda RoadSync operation  P.111
- Honda RoadSync mute

Selectable area

FAVORITE SWITCH

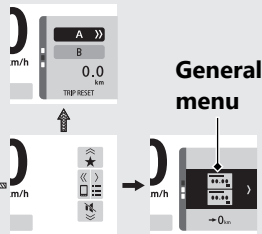



Honda RoadSync



Move to Honda RoadSync operation display.



Honda RoadSync mute

Mute audio and sound.

 Press and hold the  of the sel  switch

 Press the  of the sel  switch

 Press and hold the  of the sel  switch



 Press and hold the  of the sel  switch





Instruments *(Continued)*

FAVORITE SWITCH (TRIP RESET mode)

FAVORITE SWITCH is the same as TRIP RESET mode  **P.38**

General menu

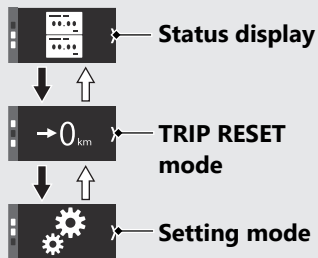

Pressing the  of the  sel switch opens the general menu.

Pressing the  or  of the sel  switch can select between the status display, tripmeter reset, and setting mode and pressing the  of the sel  switch opens each display.



 Press the  of the sel  switch

 Press the  of the sel  switch

Pressing the  of the  sel switch closes the general menu.

Pressing none of switch for about 10 seconds also closes the general menu except when the status display is selected.

Status display

Display the information selected in the FAVORITE INFO setting.

Pressing the ▲ or ▼ of the sel switch selects between the four pages.

► There are two items in a page.

The items that you can select as display information are the same as those in the INFO area.

FAVORITE INFO setting:  **P.47**

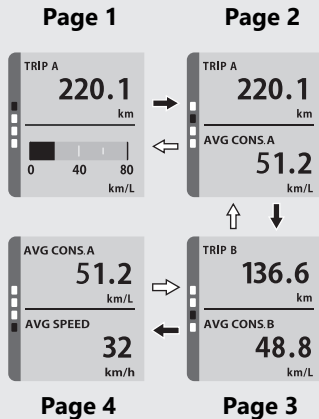



 Press ▲ of the sel switch



 Press ▼ of the sel switch

Instruments (Continued)

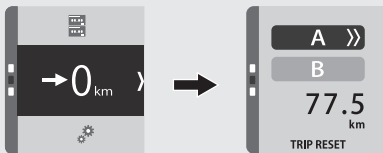

TRIP RESET mode

1. Select the TRIP RESET mode and press the  of the  sel switch.  **P.36**



2. Select the tripmeter A or B using the  or  of the  sel switch.



3. Press and hold the  of the  sel switch.
 - ▶ When the tripmeter A/B is reset, fuel consumption [CONS. A/B] and average fuel mileage [AVG CONS. A/B] based on each tripmeter are reset at the same time.
 - ▶ If button is not pressed for 10 seconds, display switches to ordinary display.

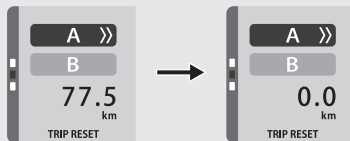



Also, the tripmeter A, tripmeter A fuel consumption, and tripmeter A average fuel mileage can be automatically reset when the fuel gauge increases 2 or more segments after refuelling.

You can turn on or off this function.

TRIP A AUTO RESET:  **P.45**

Setting mode

Press the  of the  sel switch to shift to setting mode.

▶ To shift to setting mode, stop the vehicle.

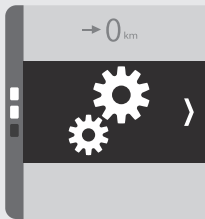



Setting mode:  P.40

Instruments *(Continued)*

Setting mode

To shift to the setting mode

Press the  of the  sel switch when the selectable area displays setting mode.  **P.36**

- ▶ The clock, indicators, and speedometer are displayed at the top of the screen while the setting mode is displayed.



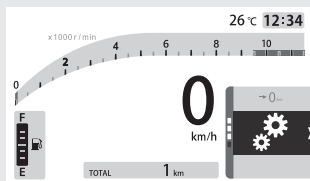

Ordinary display

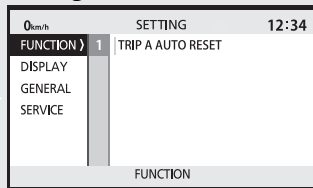

Setting mode



To return to the ordinary display

- Press the  of the  sel switch during selecting FUNCTION, DISPLAY, GENERAL, or SERVICE.
- Turn the ignition switch to the  (Off) position and to the  (On) position again.

Setting flow

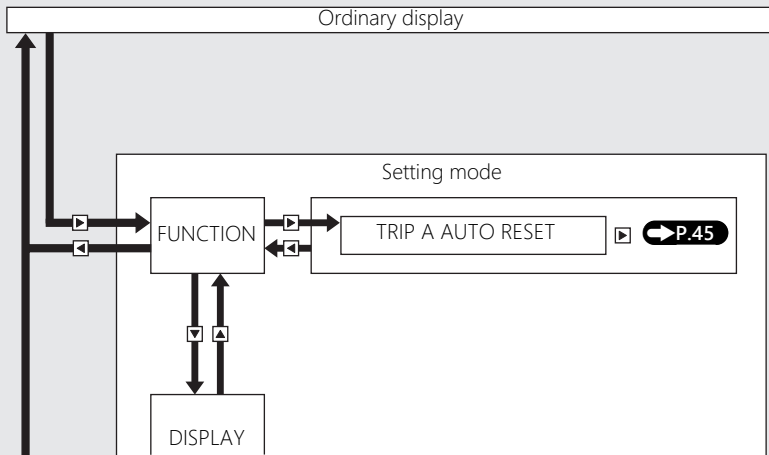

Instruments *(Continued)*

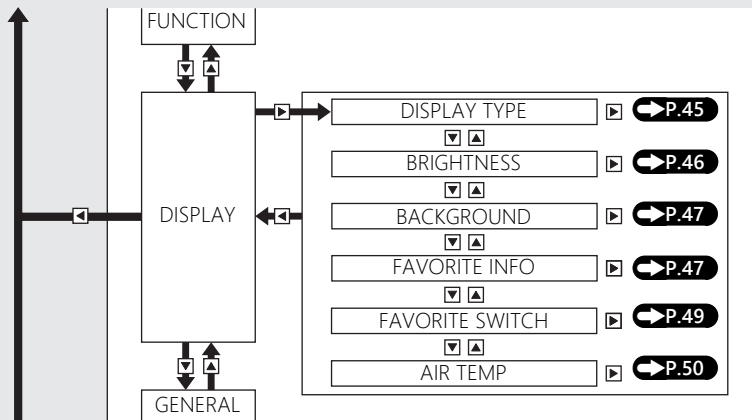

 **Push/Press**

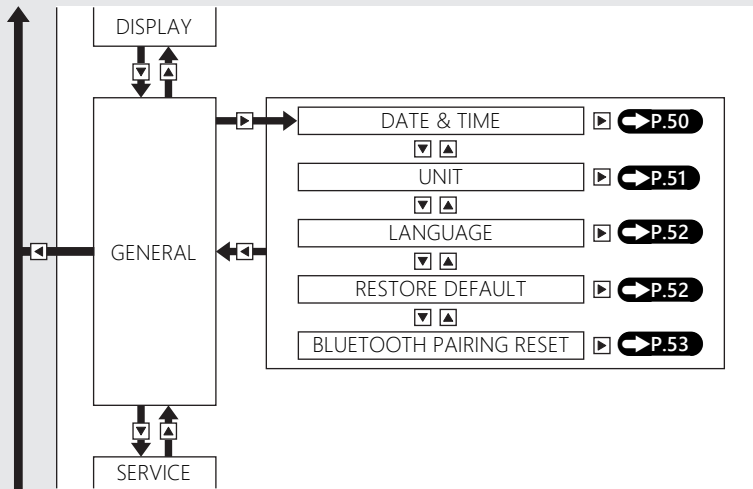

→ Push/Press

Instruments *(Continued)*

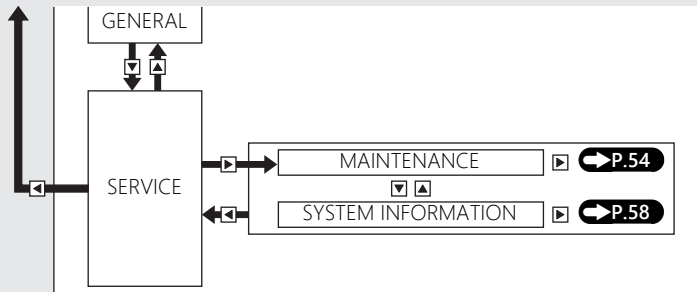

→ Push/Press

FUNCTION

TRIP A AUTO RESET

You can switch the tripmeter A automatic reset mode to the **I** (active) or **O** (inactive).

➡ P.38

- 1 Select the **I** (active) or **O** (inactive) using the **▲** or **▼** of the **↔** sel switch.
- 2 Press the **◀** of the **↔** sel switch to confirm the setting.

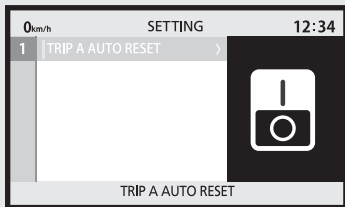

DISPLAY

DISPLAY TYPE

You can change the display type. ➡ P.24

- 1 Select the display type ("BAR", "CIRCLE", or "SIMPLE") using the **▲** or **▼** of the **↔** sel switch.
- 2 Press the **◀** of the **↔** sel switch to confirm the setting.

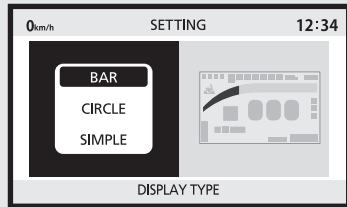



Instruments *(Continued)*

BRIGHTNESS





You can adjust the backlight brightness to one of the eight levels or select the auto adjustment.

Automatic brightness control:  **P.198**

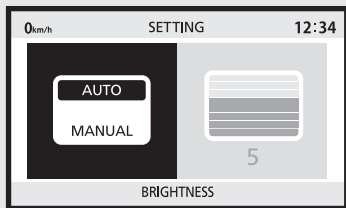
The display may become dark when the display is very hot. If it does not return to its original brightness, contact your dealer.

- ① Select the "AUTO" or "MANUAL" using the  or  of the  sel switch.



- ② If you select "MANUAL," you can switch to the backlight brightness setting by pressing the  of the  sel switch.
- ③ Select the backlight brightness using the  or  of the  sel switch.

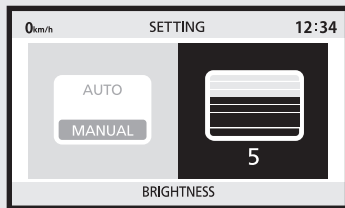

- ④ Press the  of the  sel switch to confirm the setting.

BACKGROUND

You can change the setting of the background colour to "WHITE," "BLACK," or "AUTO" adjustment.

Automatic Brightness Control: ➔ P.198

- 1 Select the background colour using the ▲ or ▼ of the ◀▶ sel switch.
- 2 Press the ◀ of the ◀▶ sel switch to confirm the setting.

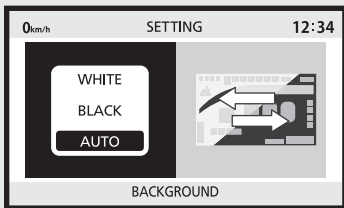

FAVORITE INFO

You can change the information items displayed in the INFO area and the status display in the selectable area. ➔ P.29



➔ P.37

INFO area

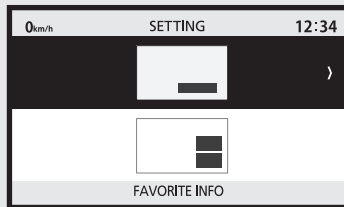
- 1 Select the INFO area using the ▲ or ▼ of the ◀▶ sel switch and press the ▶ of the ◀▶ button.



Instruments (Continued)

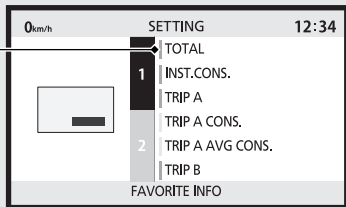

- ② Select the item using the ▲ or ▼ of the  sel switch.
- ③ Pressing the ▶ of the  sel switch can switch if the item is displayed or not.
 - ▶ When the bar turns green, the item is displayed in INFO area.





Bar

- ④ Press the ◀ of the  sel switch to confirm the setting.

Status display

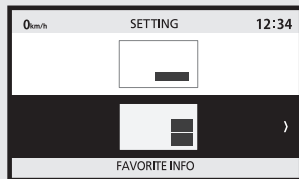
- ① Select the status display using the ▲ or ▼ of the  sel switch and press the ▶ of the sel  button.



- ② Select the page of the status display using the ▲ or ▼ of the  sel switch and press the ▶ of the sel  button.

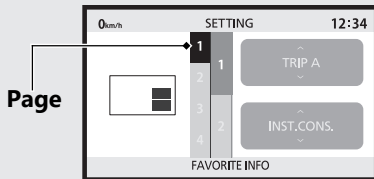

- 3 Select the tab of the status display using the ▲ or ▼ of the ⬅➡ sel switch and press the ▶ of the ⬅➡ button.

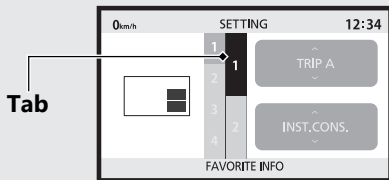

- 4 Select the item using the ▲ or ▼ of the ⬅➡ sel switch.

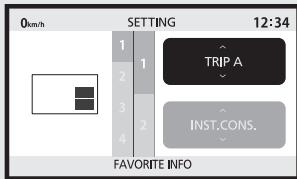

- 5 Press the ◀ of the ⬅➡ sel switch to confirm the setting.

FAVORITE SWITCH

"FAVORITE SWITCH" is displayed but not selectable.

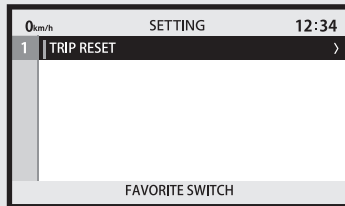

Instruments *(Continued)*

AIR TEMP

You can switch the AIR TEMP meter to the

⏏ (active) or ○ (inactive). ➡ P.26

- ① Select the ⏏ (active) or ○ (inactive) using the ▲ or ▼ of the ⏏ sel switch.
- ② Press the ◀ of the ⏏ sel switch to confirm the setting.

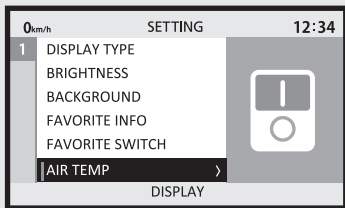

GENERAL

DATE & TIME

- ① Select the day, month, year, hour, minute, "24 / 12", and "AM / PM" using the ◀ or ▶ of the sel ⏏ switch.
- ② Select the desired setting using the ▲ or ▼ of the ⏏ sel switch.
▶ "AM / PM" is available when you select 12-hour indication.
- ③ Press the ◀ of the ⏏ sel switch to confirm the setting.

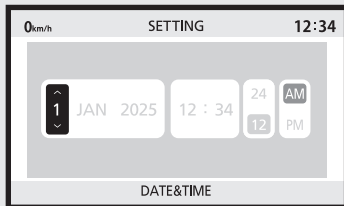

UNIT

You can change the speed unit and fuel mileage meter unit.

- ▶ "TEMP." is displayed but not selectable.
- ▶ The mileage unit is automatically changed depending on the speed unit.

- ① Select the "SPEED" or "FUEL CONS." using the ◀ or ▶ of the ⏪ sel switch.
- ② Select the desired setting using the ▲ or ▼ of the ⏪ sel switch.
- ③ Press the ◀ of the ⏪ sel switch to confirm the setting.

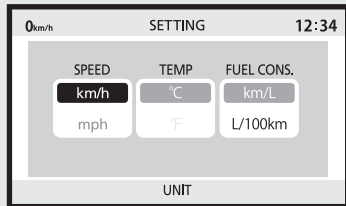

Instruments (Continued)

LANGUAGE

You can change the system language.

- 1 Select the language using the ▲ or ▼ of the ◀▶ sel switch.
- 2 Press the ▶ of the ◀▶ sel switch to change the language.
 - ▶ When language is changed, the bar changes to green
- 3 Press the ◀ of the ◀▶ sel switch to confirm the setting.

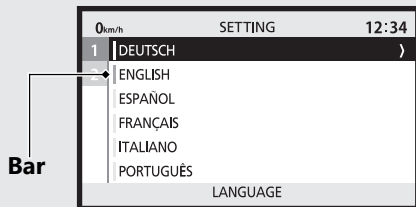

RESTORE DEFAULT

Pressing and holding the ▶ of the ◀▶ sel switch can return the set values to default settings.

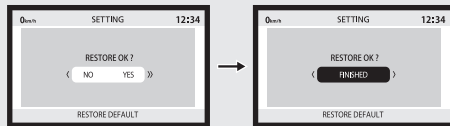

The following items are restored to their default values:

- TRIP A AUTO RESET
- DISPLAY TYPE
- BRIGHTNESS
- BACKGROUND
- FAVORITE INFO
- FAVORITE SWITCH
- UNIT
- LANGUAGE

1 BLUETOOTH PAIRING RESET

You can reset the pairing record of *Bluetooth*®.

Reset a *Bluetooth*® pairing record after stopping at a safe place.

To connect the device ➔ P.114

Make sure smartphone that you want to delete connection is connected to your vehicle.

To check if the smartphone is connected: ➔ P.25

- 1 Select the "NO" (not reset) or "YES"(reset) using ◀ or ▶ on the sel ⏏ switch.
- 2 **When the "NO" is selected**
Press the ◀ of the ⏏ sel switch. The pairing record is maintained, and then the display returns to the upper level hierarchy.

When the "YES" is selected

Press and hold the ▶ of the ⏏ sel switch. Your smartphone connection is deleted and the pairing record is reset.

- ▶ When reset is complete, "FINISHED" will be displayed.

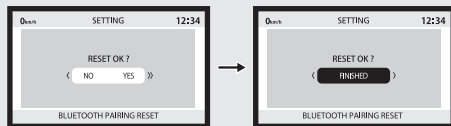

- ▶ If the pairing information remains in your smartphone even if the pairing information is deleted from the vehicle, the smartphone may be connected to the vehicle again.

Instruments (Continued)

SERVICE

MAINTENANCE

PERIODIC MAINTENANCE

You can check the next periodic inspection timing.

You can change the setting of the next periodic inspection timing.

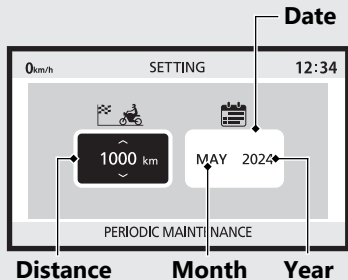

Display range:

DISTANCE:

-----, -99,999 to 12,875 km
(-99,999 to 8,000 mile)

DATE:

Month: ---, JAN to DEC
Year: ----, 2020 to 2099

Setting range:

DISTANCE:

-----, 100 to 12,000 km
(100 to 8,000 mile)

DATE:

Month: ---, JAN to DEC
Year: ----, 2020 to 2099

OIL CHANGE

You can check the next engine oil change timing.

You can change the setting of the next engine oil change timing.

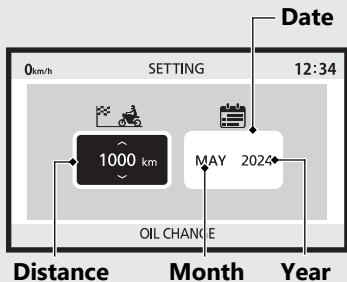

Display range:

DISTANCE:

-----, -99,999 to 12,875 km
(-99,999 to 8,000 mile)

DATE:

Month: ---, JAN to DEC
Year: ----, 2020 to 2099

Setting range:

DISTANCE:

-----, 100 to 6,000 km
(100 to 4,000 mile)

DATE:

Month: ---, JAN to DEC
Year: ----, 2020 to 2099

Instruments *(Continued)*

The pop-up information appears in the ordinary display when it reaches either of the following.  **P.59**

- 500 km (300 mile) from the next periodic inspection.
- 100 km (60 mile) from the next engine oil change.
- One month before the set month.

Periodic inspection

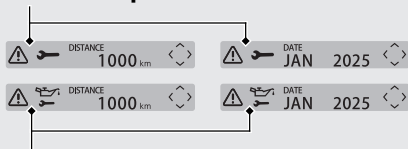

Oil change information

BATTERY VOLTAGE

Displays the current voltage.

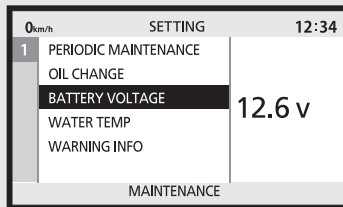

WATER TEMP

Displays the current coolant temperature.

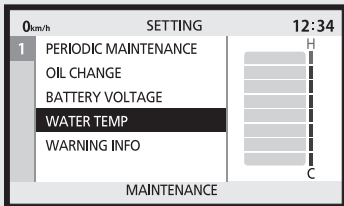

WARNING INFO

Displays each warning information and maintenance information.

- ▶ If there is no warning information to display, it displays nothing.
- ▶ If there is a warning information, see your dealer for service.

Warning information

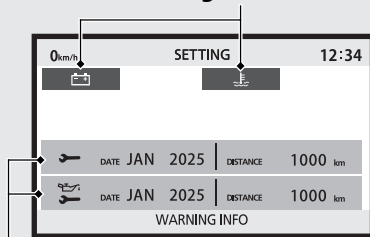

Maintenance information

Instruments *(Continued)*

SYSTEM INFORMATION

Displays the system information.

0km/h	SETTING	12:34
1	SOFTWARE VERSION	XXXXXXXXXXXX
	HARDWARE INFOMATION	XXX-XX

SYSTEM INFORMATION

Pop-up information













In the following cases, pop-up information appear at the INFO area.

- Maintenance information:
When the inspection timing of your vehicle is approaching.
- Warning indicator:
When malfunction is detected.

When your vehicle has multiple pieces of information, pop-up information display appears alternately.



Pushing any of the  sel switch can hide the pop-up information.

Maintenance Information

Indication	Explanation	Remedy
  DISTANCE 1000 km 	When the periodic inspection timing of your vehicle is approaching.	Have your vehicle inspected by your dealer.
  DATE JAN 2025 		
  DISTANCE 1000 km 	When the oil change timing of your vehicle is approaching.	Change the engine oil.
  DATE JAN 2025 		

Instruments *(Continued)*

Warning Information

Indication	Explanation	Remedy
	High coolant temperature indicator	If it comes on while riding: ➡ P.169
	Battery charging condition indicator	If it comes on while riding: ➡ P.170

Instruments (Continued)

MA type

Tachometer

Tachometer red zone
(excessive engine rpm range)

NOTICE

Do not operate the engine in the tachometer red zone. Excessive engine speed can adversely affect engine life.

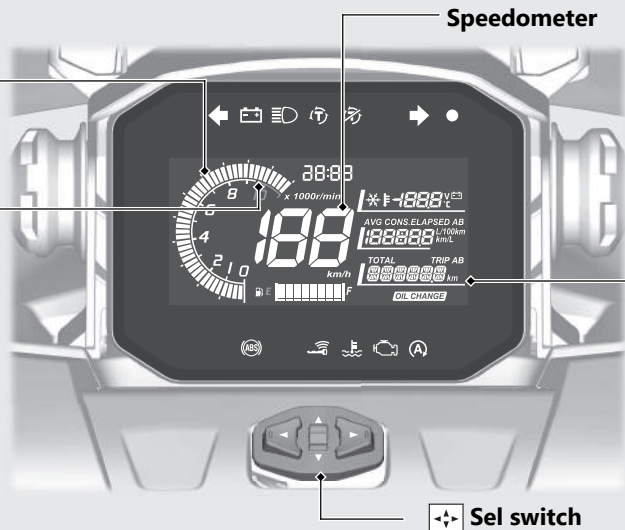

Speedometer

Sel switch

Display Check

When the ignition switch is turned to the **I** (On) position, initial animation will show. If any part of these displays does not come on when it should, have your dealer check for problems.

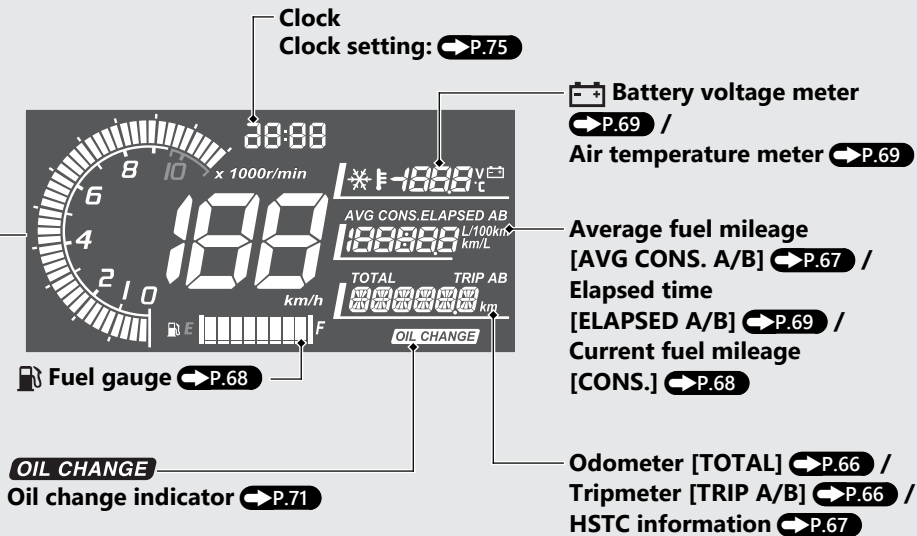

Instruments (Continued)

Switching the Display

Select the info area

Press the ▲ or ▼ of the ◀▶ sel switch to move the cursor to a desired info area.

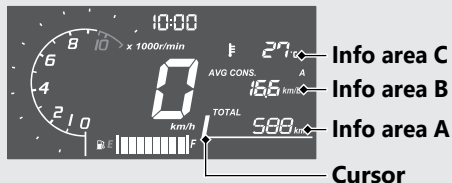

Info area C

Info area B

Info area A



Select the item

Press the sel switch to the or to a desired item.

Info area A

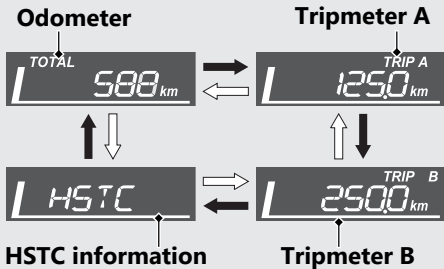

Press sel switch to the

Press sel switch to the

Info area B

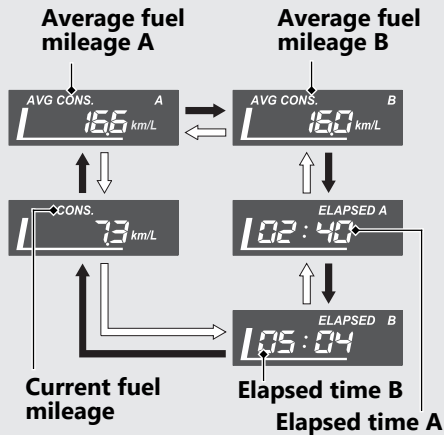



Press sel switch to the

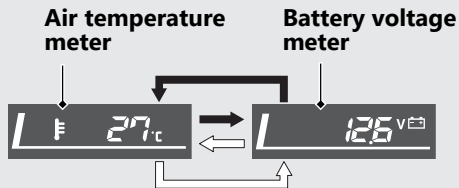

Press sel switch to the

Instruments *(Continued)*

Info area C



➡ Press  sel switch to the 

⇨ Press  sel switch to the 

| Odometer

Total distance ridden.

When "-----" is displayed, go to your dealer for service.

| Tripmeter



Distance ridden since tripmeter A or tripmeter B respectively were reset.

When "-----.-" is displayed, go to your dealer for service.

To reset the tripmeter:  **P.70**

HSTC information

You can switch Honda Selectable Torque Control on/off while HSTC information is selected.

To switch HSTC, press and hold the  sel switch to the .

- ▶ Torque control OFF indicator comes on when HSTC is turned off.

Average fuel mileage A/B

Displays the average fuel mileage since the selected tripmeter was reset.

The average fuel mileage will be calculated based on value displayed on the tripmeter (A or B) selected.

Display range:

0.0 to 299.9 km/L (L/100 km)

- When the tripmeter A or B is reset: "---.-" is displayed.
- If the calculated value is above 299.9 km/L (L/100 km): "299.9" is displayed.

When "---.-" is displayed except for the above-mentioned cases, go to your dealer for service.

To reset the average fuel mileage:

 **P.70**

Instruments *(Continued)*

Current fuel mileage

Displays the current fuel mileage.

Display range:

0.0 to 299.9 km/L (L/100 km)

- When your speed is below 5 km/h (3 mph): "---.-" is displayed.
- If the calculated value is above 299.9 km/L (L/100 km): "299.9" is displayed.

When "---.-" is displayed except for the above-mentioned cases, go to your dealer for service.

Fuel gauge

Remaining fuel when only 1st (E) segment starts flashing: approximately 1.32 L (0.349 US gal, 0.290 Imp gal)



NOTICE

You should refuel when the reading approaches the 1st (E) segment. Running out of fuel can cause the engine to misfire, damaging the catalytic converter.

If the fuel gauge indicator flashes in a repeat pattern or turns off ➔ **P.176**

| Air temperature meter

Shows ambient temperature.

Display range: -10 to 50°C

- Below -10°C: "---" is displayed
- 50°C or more: 50°C blinks

❄ comes on when air temperature is 3°C or less, and goes off when air temperature reaches 5°C after ❄ comes on.

The temperature readout may be incorrect at low speeds due to reflected heat.

| Battery voltage meter

Displays the current voltage.

| Elapsed time A/B

Displays the elapsed time during the engine running since the selected tripmeter was reset.

Display range: 00:00 to 199:59
(hours:minutes)

- The elapsed time return to 00:00 when the readout exceeds 199:59.

To reset the elapsed time:  **P.70**

Instruments *(Continued)*

To reset the tripmeter A, average fuel mileage A, and elapsed time A

- 1 Select the info area A. P.64
- 2 Select the tripmeter A. P.65
- 3 Press and hold the sel switch to the .



- ▶ Even if average fuel mileage A or elapsed time A is not selected in the info area, average fuel mileage A and elapsed time A will be reset.

The display after resetting the tripmeter

Average fuel mileage A



Elapsed time A



To reset the tripmeter B, average fuel mileage B, and elapsed time B

- 1 Select the info area A. P.64
- 2 Select the tripmeter B. P.65
- 3 Press and hold the sel switch to the .



- ▶ Even if average fuel mileage B or elapsed time B is not selected in the info area, average fuel mileage B and elapsed time B will be reset.

The display after resetting the tripmeter

Average fuel mileage B



Elapsed time B



Oil change indicator

The indicator is turned on whenever the running distance reaches the programmed oil change interval.

When the oil change indicator is appeared, reset the indicator after changing the engine oil.

- ▶ The oil change indicator is appeared for the first time when the running distance reaches 1,000 km.
- ▶ The oil change indicator is appeared when the running distance reaches every 6,000 km after the first indication was reset.



Oil change indicator

If the oil is changed before the oil change indicator comes on, be sure to reset the oil change indicator after changing the oil.

To reset the oil change indicator

➔ P.72

You can also check the remaining distance to next interval of the oil change.

To check the remaining distance

➔ P.72

Instruments *(Continued)*

To check the remaining distance

You can check the remaining distance to next interval of the oil change and maintenance. When the ◀ and ▶ of the ↕ sel switch is pressed together, remaining distance appears briefly.

Remaining oil change distance



To reset the oil change indicator

- 1 Turn the ignition switch to the ○ (Off) position.

- 2 Press and hold the ◀ and ▶ of the ↕ sel switch while turning the ignition switch to the I (On) position and keep holding them until the oil change indicator distance starts flashing.



- ▶ The button is not pressed for about 30 seconds, the control is automatically switched the ordinary display.

- 3 Press and hold the ↕ sel switch to the ▶. The oil change indicator and remaining distance are reset.



- ▶ If you do not reset the oil change indicator, press the ▼ of the ↕ sel switch.

Display Setting

Following items to change sequentially.



- Time format setting
- Clock setting
- Backlight brightness adjustment
- Changing of fuel mileage meter unit

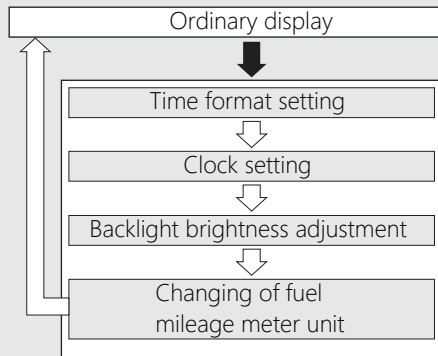

If the ignition switch is turned to the  (Off) position or the button is not pressed for about 30 seconds, the control is automatically switched from the setting mode to the ordinary display.

If the button is not pressed for about 30 seconds items in the process of being set will be discarded and only items where settings have been finalized will be applied.

Only if the ignition switch is turned to the  (Off) position will items in the process of being set and those that are finalized be applied.



➡ Press and hold the  and  of the  sel switch

➡ Press the  sel switch to the 

Instruments *(Continued)*

1 Time format setting:

You can switch the time format between 12 hour format or 24 hour format.

- 1 Turn the ignition switch to I (On) position.
- 2 Press and hold the ◀ and ▶ of the ⏏ sel switch, and the current time format starts flashing.

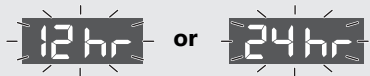

- 3 Press the ▲ or ▼ of the ⏏ sel switch to select "12 hr" or "24 hr."



- 4 Press the ⏏ sel switch to the ▶. The time format is set, and then the display moves to the clock setting.

2 Clock setting:

- 1 Press the ▲ or ▼ of the sel switch until the desired hour is displayed.
 - ▶ Press and hold the sel switch to the ▲ to advance the hour fast.



- 2 Press the sel switch to the ▶. The minute digits start flashing.



- 3 Press the ▲ or ▼ of the sel switch until the desired minute is displayed.
 - ▶ Press and hold the sel switch to the ▲ to advance the minute fast.

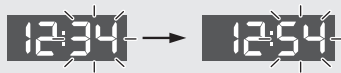



- 4 Press the sel switch to the ▶. The clock is set, and then the display moves to the backlight brightness adjustment.



Instruments *(Continued)*

3 Backlight brightness adjustment:

You can adjust the brightness to one of five levels.

- 1 Press the  or  of the  sel switch.
The brightness is switched.





- 2 Press the  sel switch to the .
- The backlight is set, and then the display moves to the changing of the fuel mileage meter unit.

4 Changing of fuel mileage meter unit:

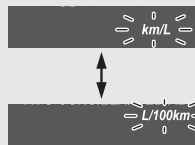
- 1 Press the  or  of the  sel switch to select "km/L" or "L/100km."



- 2 Press the  sel switch to the .
- The fuel mileage unit is set, and then the display moves to the ordinary display.

Indicators

III MA, VII MA type

If any of these indicators does not come on when it should, have your dealer check for problems.

Refer to the “Instruments” about indicators appeared on the display: **➡ P.25**

↶ Left turn signal indicator

↷ Right turn signal indicator



📶 Honda SMART Key Indicator

Comes on when vehicle and Honda SMART Key verification is complete, and the ignition switch can be operated.

Goes off when the ignition switch is turned to the **I** (On) position.

When the Honda SMART Key indicator flashes: ➡ P.173

(ABS) ABS (Anti-lock Brake System) indicator

- Comes on when the ignition switch is turned to the **I** (On) position.
- Goes off when your speed reaches approximately 10 km/h (6 mph).

If it comes on while riding: ➡ P.171

Torque Control indicator

- Comes on when the ignition switch is turned to the **I** (On) position. Goes off when your speed reaches approximately 3 km/h (2 mph) to indicate Torque Control is ready to work.
- Blinks when Torque Control is operating.

If it comes on while riding:

 **P.172**



PGM-FI (Programmed Fuel Injection) malfunction indicator lamp (MIL)

Comes on briefly when the ignition switch is turned to the **I** (On) position.

If it comes on while engine is running:

 **P.170**



Idling Stop indicator

Comes on briefly when the Idling Stop switch in the **(A)** (Idling Stop) position with the ignition switch turned to **I** (On) position.



Alarm indicator **P.98**

Torque Control OFF Indicator

Comes on when the Torque Control is turned off.

Indicators (Continued)

MA type

If any of these indicators does not come on when it should, have your dealer check for problems.

 **Left turn signal indicator**

 **High beam indicator**

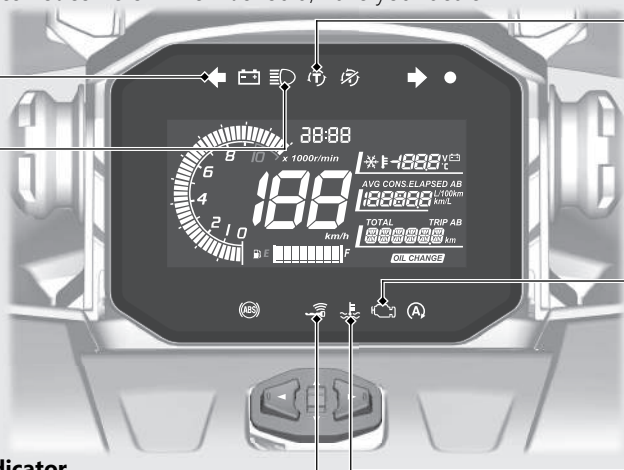

 **Honda SMART Key Indicator**

Comes on when vehicle and Honda SMART Key verification is complete, and the ignition switch can be operated. Goes off when the ignition switch is turned to the **I** (On) position.

When the Honda SMART Key indicator flashes:  **P.173**

 **Torque Control indicator**

- Comes on when the ignition switch is turned to the **I** (On) position. Goes off when your speed reaches approximately 3 km/h (2 mph) to indicate Torque Control is ready to work.
- Blinks when Torque Control is operating.

If it comes on while riding:  **P.172**

 **PGM-FI (Programmed Fuel Injection) malfunction indicator lamp (MIL)**

Comes on briefly when the ignition switch is turned to the **I** (On) position, regardless of engine stop switch position.

If it comes on while engine is running:  **P.170**

 **High coolant temperature indicator**

Comes on briefly when the ignition switch is turned to the **I** (On) position.

If it comes on while riding:  **P.169**

Indicators *(Continued)*

 **Battery Charging Condition indicator**

If it comes on while riding:  **P.170**

 **Right turn signal indicator**

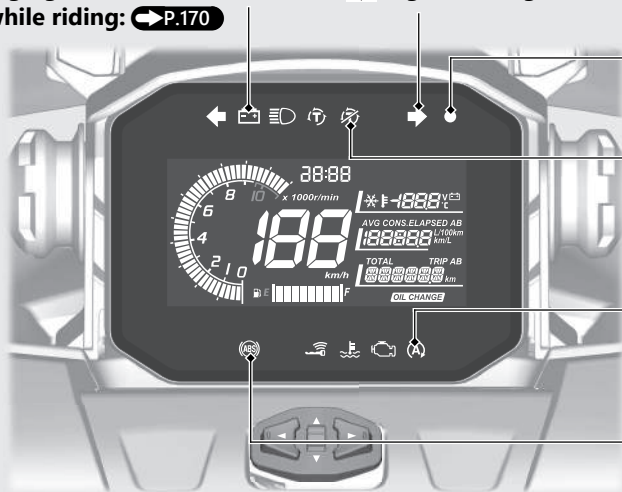

Alarm indicator  **P.98**

 **Torque Control OFF indicator**

Comes on when the Torque Control is turned to off.

 **Idling Stop Indicator**

Comes on when the idling stop system is on.

Idling stop system:  **P.116**

 **ABS (Anti-lock Brake System) indicator**

Comes on when the ignition switch is turned to the **I** (On) position.
Goes off when your speed reaches approximately 10 km/h (6 mph).

If it comes on while riding:  **P.171**

Switches

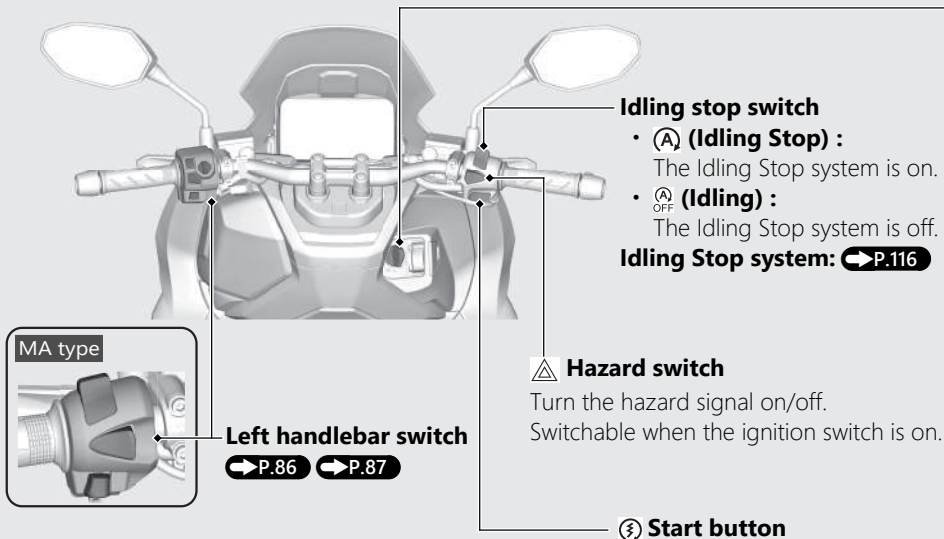

Idling stop switch

- **(A) (Idling Stop) :**
The Idling Stop system is on.
- **(A OFF) (Idling) :**
The Idling Stop system is off.

Idling Stop system: ➔ P.116

Hazard switch

Turn the hazard signal on/off.
Switchable when the ignition switch is on.

Start button

Left handlebar switch

➔ P.86 ➔ P.87

MA type

Ignition switch

Switches the electrical system on/off, locks the steering, and operates the fuel lid and seat opener switch.

To unlock the ignition switch:  **P.94**

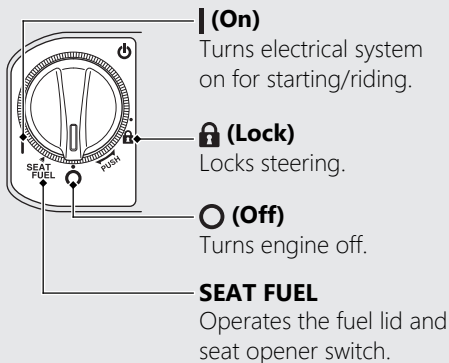

Answer back/alarm button

This button is used to operate the answer back system and the anti-theft alarm system.

Answer Back System:  **P.105**

Anti-theft Alarm System:

 **P.98**

ON/OFF button

This button is used to activate or deactivate the Honda SMART Key system, and also to confirm the activation status.  **P.90**



Switches *(Continued)*

Left handlebar switch

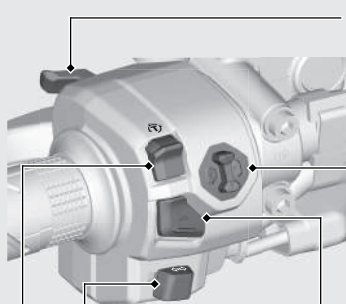
III MA, VII MA type



Headlight dimmer/Passing light control switch

-  : High beam
-  : Low beam
-  **PASS** : Flashes the high beam headlight.

Sel switch

Used to operate and set the display and the Honda RoadSync.  **P.111**

Horn button

Turn signal switch

 Pressing the switch turns the turn signals off.

Torque Control switch

Press and hold to turn the Torque Control on and off.  **P.121**

MA type

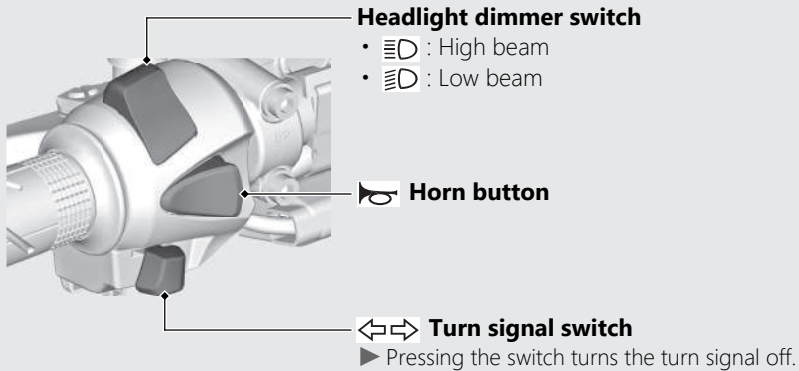

Switches *(Continued)*

Steering Lock

Lock the steering when parking to help prevent theft.

A U-shaped wheel lock or similar device is also recommended.

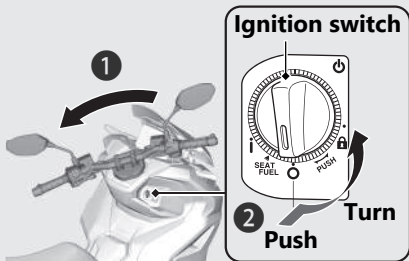

Locking

- 1 Turn the handlebar all the way to the left or right.
- 2 Push the ignition switch down, and turn it to the  (Lock) position.
 - ▶ To unlock the ignition switch. ➔ **P.94**
 - ▶ Jiggle the handlebar if the lock is difficult to engage.
- 3 Lock the ignition switch.

Unlocking

Push the ignition switch in, and turn it to the

 (Off) position.

- ▶ To unlock the ignition switch. ➔ **P.94**

Honda SMART Key System

The Honda SMART Key system allows you to operate the main switch without inserting a key into a keyhole.

The system runs a two-way authentication between the vehicle and the Honda SMART Key to verify if it is the registered Honda SMART Key.

The Honda SMART Key system uses low-intensity radio waves. It may affect medical equipment such as a cardiac pacemaker.

Honda SMART Key System *(Continued)*

Switching the Honda SMART Key System

To switch the Honda SMART Key system to activation or deactivation

Press the ON/OFF button until the Honda SMART Key LED changes colour.

To check the Honda SMART Key system status

Lightly press the ON/OFF button. The Honda SMART Key LED will show the status.

When the Honda SMART Key LED is:

Green: Honda SMART Key system authentication can be performed.

Red: Honda SMART Key system authentication cannot be performed.

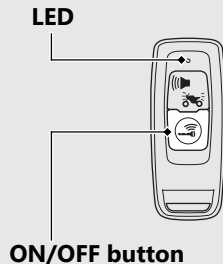

Operating Range

The operating range varies when the ignition switch is locked or unlocked.

The Honda SMART Key system uses low-intensity radio waves. Therefore, the operating range may be wider or narrower, or the Honda SMART Key system may not work properly in the following situations:

- When the Honda SMART Key battery is depleted.
- When there are facilities nearby that generate strong radio waves or noise, such as TV towers, power stations, radio stations, or airports.
- When you carry the Honda SMART Key with a laptop or wireless communication device such as a radio or mobile phone.
- When the Honda SMART Key comes into contact with or is covered by metal objects.

When the ignition switch is unlocked:

The system can be operated within the shaded area shown in the illustration.

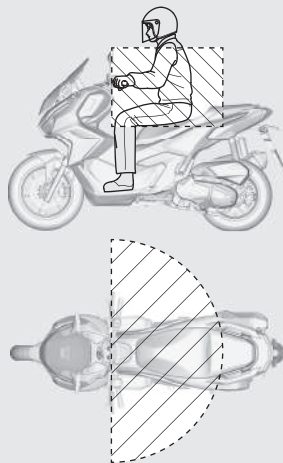

Honda SMART Key System *(Continued)*

When the ignition switch is locked:

The system can be operated within the shaded area shown in the illustration.

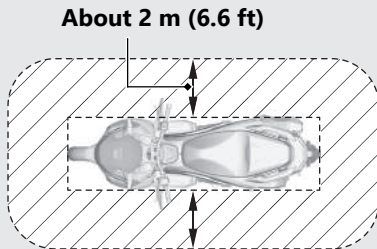

Anyone can unlock the ignition switch and start the engine if your Honda SMART Key is within operating range of your vehicle, even if you are on the other side of a wall or window. If you are away from your vehicle but your Honda SMART Key is still within operating range, deactivate the Honda SMART Key system.

To switching the Honda SMART Key system → P.90

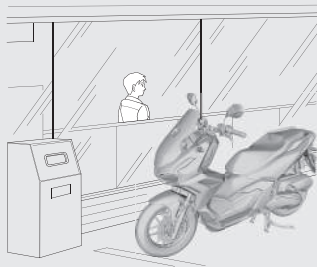

Anyone in possession of the Honda SMART Key can perform the following operations if the Honda SMART Key is within operating range:

- Starting the engine
- Unlocking the ignition switch
- Releasing the seat lock
- Opening the fuel lid
- Unlocking the steering lock

You should always keep the Honda SMART Key on your person after you get on and off the vehicle or while riding.

Do not store the Honda SMART Key in any compartment.

If the ignition switch is in the **I** (On) position, the vehicle can be operated even by a person who does not have a verified Honda SMART Key.

Whenever you leave your vehicle, lock the steering and lock the ignition switch.

➡ P.95

Make sure the ignition switch ring goes off and all turn signals flash once at this time.

The buzzer also rings at this time.

- ▶ The buzzer sound can be cancelled.

➡ P.97

Honda SMART Key System *(Continued)*

Switching the ignition switch

To Unlock the Ignition Switch

- 1 Make sure that the Honda SMART Key is active. **➡ P.90**
- 2 To authenticate the Honda SMART Key system, push the ignition switch.
 - ▶ When properly authenticated and the ignition switch is unlocked, the Honda SMART Key indicator and ignition switch ring come on. The buzzer also rings 2 times at this time.
 - ▶ The buzzer sound can be cancelled.
➡ P.97
- 3 Turn the ignition switch to the **I** (On) position while the Honda SMART Key indicator comes on.
 - ▶ If you do not turn the ignition switch to the **I** (On) position within 20 seconds after you push the ignition switch in, the Honda SMART Key indicator and ignition switch ring will go off, the turn signals flash 1 time, and then the ignition switch will be locked. The buzzer also rings 1 time.
 - ▶ The buzzer sound can be cancelled.
➡ P.97

When the Honda SMART Key system does not work properly **➡ P.181**

If someone without the Honda SMART Key tries to turn the ignition switch, the ignition switch rotates freely. If you notice the ignition switch is in a different position, turn the ignition switch to the original (○ (Off) or 🔒 (Lock)) position.

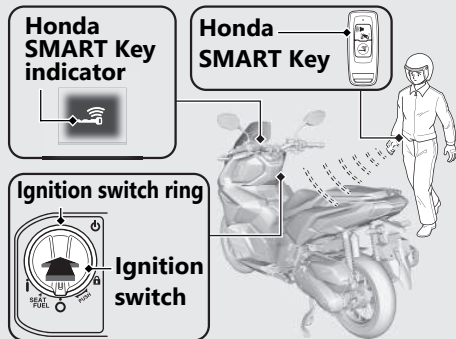

To Lock the Ignition Switch

- 1 Turn the ignition switch to the SEAT FUEL, ○ (Off), or 🔒 (Lock) position.
- 2 Lock the ignition switch by doing one of the following:
 - Leave the operating range with the Honda SMART Key. ➡ P.91
 - Push the ignition switch.
 - Wait for approximately 20 seconds after turning the ignition switch from | (On) to SEAT FUEL, ○ (Off) or 🔒 (Lock).
 - Switch the Honda SMART Key system to inactive. ➡ P.90
 - Press the answer back/alarm button on the Honda SMART Key.
 - ▶ At the same time, the anti-theft alarm system is set. ➡ P.100



Honda SMART Key System *(Continued)*

- ③ Make sure that the Honda SMART Key indicator and ignition switch ring go off and the turn signals flash once. This indicates that the ignition switch is locked. The buzzer also rings 1 time at this time.
- ▶ The buzzer sound can be cancelled.

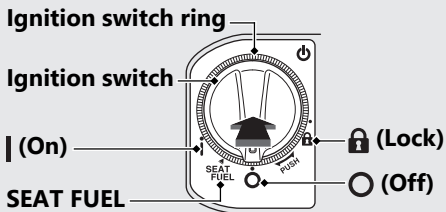

➡ P.97

When the Honda SMART Key system does not work properly ➡ P.181



Always make sure the ignition switch position is in the  (Off) or  (Lock) position when you leave your vehicle.

When the ignition switch is locked in the SEAT FUEL position, the ignition switch can be turned  (Off) only once.

When the ignition switch is locked in the  (Off) position, the steering cannot be locked. To lock the steering, unlock the ignition switch.  **P.88**  **P.94**

Switch the Buzzer Sound When the Ignition Switch is Locked/Unlocked

Enable

- 1 Deactivate the Honda SMART Key system.
 **P.90**
- 2 Lightly press the ON/OFF button. The red Honda SMART Key LED comes on.
- 3 While the red LED is on, press the answer back/alarm button.
 - ▶ The red LED starts blinking when the buzzer sound is properly enabled.

Disable

- 1 Deactivate the Honda SMART Key system.
 **P.90**
- 2 Lightly press the ON/OFF button. The red Honda SMART Key LED blinks.
- 3 While the red LED is blinking, press the answer back/alarm button.
 - ▶ The red LED stops blinking but stays on when the buzzer sound is properly disabled.



Anti-theft Alarm System

The anti-theft alarm system is a device to reduce the likelihood of theft. When the sensor detects vibration or movement with the ignition switch in the **○** (Off) or **🔒** (Lock) position and the system is set, the alarm is activated.

The buzzer rings and the turn signals blink for about 10 seconds when the anti-theft alarm system detects vibration caused by contact or movement.

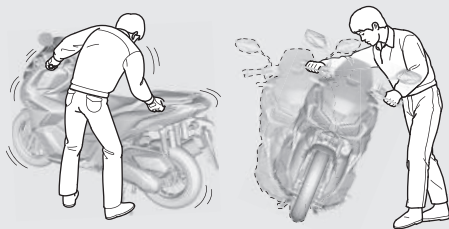
The buzzer rings and the turn signals blink for about 60 seconds when the anti-theft alarm system detects a substantial change in the vehicle posture. After the buzzer rings for 60 seconds, the anti-theft alarm system will be reset in that posture.





If the ignition switch is left in the  (Off) or  (Lock) position for more than 10 days, the anti-theft alarm system will no longer operate. When the system is active and the vehicle receives a signal from pressing the answer back/alarm button, system activation will be extended for 10 days. To reset the system, turn the ignition switch to the  (On) position once.

The anti-theft alarm system uses low-intensity radio waves. It may affect medical equipment such as a cardiac pacemaker.

When the battery in the vehicle is weak, the anti-theft alarm system may not function.

Anti-theft Alarm System *(Continued)*

Setting the Anti-theft Alarm System

- 1 Turn the ignition switch to  (Off) or  (Lock) position.
- 2 Press the answer back/alarm button. Within a second, the turn signals blink and the buzzer rings 1 time. After 2.5 seconds, the buzzer rings 1 time. The anti-theft alarm system is activated.

The alarm indicator flashes while the anti-theft alarm system is activated.

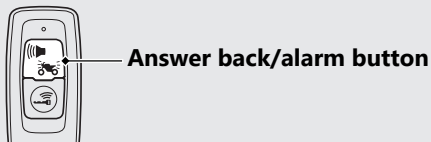

III MA, VII MA type



Alarm indicator

MA type

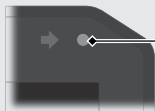

■ Cancelling the Anti-theft Alarm System

To cancel the anti-theft alarm system, unlock the ignition switch. ➔ **P.94**

When the anti-theft alarm system is cancelled, the alarm indicator goes off and the buzzer rings 2 times.

- ▶ The buzzer sound can be cancelled.

➔ **P.97**

■ Stopping the Anti-theft Alarm Activation

To stop the anti-theft alarm activation, do one of the following:

- Press the answer back/alarm button on the Honda SMART Key.
 - ▶ After stopping the anti-theft alarm activation, the anti-theft alarm system will be reset.
- Unlock the ignition switch. ➔ **P.94**
 - ▶ After stopping the anti-theft alarm activation, the anti-theft alarm system will be cancelled.



**Answer back/
alarm button**

Anti-theft Alarm System *(Continued)*

Adjusting the Sensitivity of Anti-theft Alarm System

You can select from 3 sensitivity levels for the anti-theft alarm system.

- 1 Make sure that the Honda SMART Key system is active. **→ P.90**
- 2 Push the ignition switch to authenticate the Honda SMART Key system. **→ P.94**
- 3 Press and hold the ignition switch for more than 4 seconds.
 - ▶ The Honda SMART Key indicator and ignition switch ring blink.

Answer back/ alarm button



Ignition switch

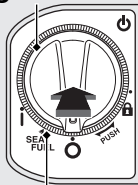

Ignition switch ring

- 4 Press the ignition switch 1 time while the Honda SMART Key indicator and ignition switch ring are blinking.
 - ▶ The Honda SMART Key indicator and ignition switch ring come on, and a buzzer sounds.
- 5 Repeat the following 3 times:
 - ▶ Press the answer back/alarm button on the Honda SMART Key 4 times and the ignition switch 1 time.
 - ▶ When the ignition switch is pressed, the Honda SMART Key indicator and ignition switch ring go off, and the buzzer sounds. Make sure the Honda SMART Key indicator and ignition switch ring come on again before next input.
 - ▶ When the answer back/alarm button is pressed, the Honda SMART Key LED comes on. Make sure the LED goes off before pressing the button again.

- ▶ When the answer back/alarm button or ignition switch is not pressed for 1 minute, the Honda SMART Key indicator and ignition switch ring blink 3 times, and then the buzzer sounds and the mode is cancelled. Return to ❶ and do the procedure again.
 - ▶ If you press the answer back/alarm button the wrong number of times before you repeat the procedure 3 times, then repeat the procedure 3 times again.
- ❶ Press the answer back/alarm button to select from 3 sensitivity levels.
 - 3 alarm rings: high sensitivity
 - 2 alarm rings: medium sensitivity
 - 1 alarm ring: low sensitivityThe Honda SMART Key indicator and ignition switch ring come on while setting.
 - ❷ Press and hold the ignition switch for more than 2 seconds. The sensitivity level is set.
 - ▶ The Honda SMART Key indicator and ignition switch ring turn off, and a buzzer sounds once.
 - ▶ When the answer back/alarm button is not pressed for 10 seconds, the Honda SMART Key indicator and ignition switch ring blink 3 times, and then the buzzer sounds, and the sensitivity level is set.

Anti-theft Alarm System *(Continued)*

If the Anti-Theft Alarm System Does Not Operate Properly

If any of the following situations arise, the battery (➔P.152) in the vehicle may be discharged or there is a system problem. Remove the battery and see your dealer.

- The alarm does not ring.
- The alarm rings but fades out.
- The alarm system does not stop.

Answer Back System

The answer back system is a device to find the location of your vehicle. When the immobilizer is active and you press the answer back/alarm button on Honda SMART Key with the ignition switch is in the **○** (Off) or **🔒** (Lock) position and the anti-theft alarm system is set, the turn signals light, the ignition switch ring lights, and the buzzer rings informing you of your vehicle's location. The ignition switch ring will light for about 1 minute.

▶ Set the anti-theft alarm system. **➡ P.100**

The answer back system uses low-intensity radio waves. It may affect medical equipment such as a cardiac pacemaker.

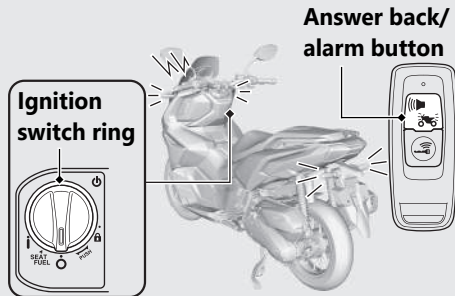

Answer Back System *(Continued)*

Operation

Press the answer back/alarm button on the Honda SMART Key.

- ▶ The answer back system will not function when the ignition switch is **I** (On) position.

If the ignition switch is left in the **O** (Off) or **L** (Lock) position for more than 10 days, the answer back system will no longer operate. When the system is activating and the vehicle receives a signal from pressing the answer back/alarm button, system activation will be extended for 10 days.

To reset the system, turn the ignition switch to the **I** (On) position once.

- ▶ To unlock the ignition switch. **➡P.94**

When the battery in the vehicle is weak, the answer back system may not function.

Adjusting the Answer Back Buzzer Sound Volume Level

You can select 3 buzzer sound volume levels.

- 1 Make sure that the Honda SMART Key system is active. **➡P.90**
- 2 Push the ignition switch to authenticate the Honda SMART Key system. **➡P.94**
- 3 Press and hold the ignition switch for more than 4 seconds.
 - ▶ The Honda SMART Key indicator and ignition switch ring blink.

Answer back/ alarm button



Ignition switch

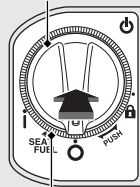

Ignition switch ring

- 4 Press the ignition switch 1 time while the Honda SMART Key indicator and ignition switch ring are blinking.
 - ▶ The Honda SMART Key indicator and ignition switch ring come on, and a buzzer sounds.
- 5 Repeat the following 3 times:
Press the answer back/alarm button on the Honda SMART Key 2 times and the ignition switch 1 time.
 - ▶ When the ignition switch is pressed, the Honda SMART Key indicator and ignition switch ring go off, and the buzzer sounds. Make sure the Honda SMART Key indicator and ignition switch ring come on again before next input.
 - ▶ When the answer back/alarm button is pressed, the Honda SMART Key LED comes on. Make sure the LED goes off before pressing the button again.
- ▶ When the answer back/alarm button or ignition switch is not pressed for 1 minute, the Honda SMART Key indicator and ignition switch ring blink 3 times, and then the buzzer sounds and the mode is cancelled. Return to 1 and do the procedure again.
- ▶ If you press the answer back/alarm button the wrong number of times before you repeat the procedure 3 times, then repeat the procedure 3 times again.
- 6 Press the answer back/alarm button to select from 3 levels for the sound volume. The Honda SMART Key indicator and ignition switch ring come on while setting.

Answer Back System *(Continued)*

- 7 Press and hold the ignition switch for more than 2 seconds. The sound volume level is set.
- ▶ The Honda SMART Key indicator and ignition switch ring turn off, and a buzzer sounds once.
 - ▶ When the answer back/alarm button is not pressed for 10 seconds, the Honda SMART Key indicator and ignition switch ring blink 3 times, and then the buzzer sounds, and the sound volume level is set.

Changing the Answer Back Buzzer Sound Pattern

You can select 3 buzzer sound patterns.

- 1 Make sure that the Honda SMART Key system is active. ➡ **P.90**
- 2 Push the ignition switch to authenticate the Honda SMART Key system. ➡ **P.94**
- 3 Press and hold the ignition switch for more than 4 seconds.
 - ▶ The Honda SMART Key indicator and ignition switch ring blink.

Answer back/
alarm button



Ignition switch

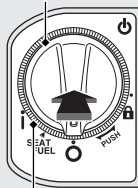

Ignition switch ring

- 4 Press the ignition switch 1 time while the Honda SMART Key indicator and ignition switch ring are blinking.
 - ▶ The Honda SMART Key indicator and ignition switch ring come on, and a buzzer sounds.
- 5 Repeat the following 3 times:
Press the answer back/alarm button on the Honda SMART Key 3 times and the ignition switch 1 time.
 - ▶ When the ignition switch is pressed, the Honda SMART Key indicator and ignition switch ring go off, and the buzzer sounds. Make sure the Honda SMART Key indicator and ignition switch ring come on again before next input.
 - ▶ When the answer back/alarm button is pressed, the Honda SMART Key LED comes on. Make sure the LED goes off before pressing the button again.
- ▶ When the answer back/alarm button or ignition switch is not pressed for 1 minute, the Honda SMART Key indicator and ignition switch ring blink 3 times, and then the buzzer sounds and the mode is cancelled. Return to 1 and do the procedure again.
- ▶ If you press the answer back/alarm button the wrong number of times before you repeat the procedure 3 times, then repeat the procedure 3 times again.
- 6 Press the answer back/alarm button to select from 3 buzzer sound patterns. The Honda SMART Key indicator and ignition switch ring come on while setting.

Answer Back System *(Continued)*

- 7 Press and hold the ignition switch for more than 2 seconds. The sound pattern is set.
 - ▶ The Honda SMART Key indicator and ignition switch ring turn off, and a buzzer sounds once.
 - ▶ When the answer back/alarm button is not pressed for 10 seconds, the Honda SMART Key indicator and ignition switch ring blink 3 times, and then the buzzer sounds, and the sound pattern is set.

Temporary Silence Mode

Temporary silence mode is the immediate way to turn off the answer back system buzzer sound.

Enable:

Press and hold the answer back/alarm button for about 2 seconds, the Honda SMART Key LED changes to red.

Disable:

Re-press and hold the answer back/alarm button for about 2 seconds, the Honda SMART Key LED changes to green.

Honda RoadSync

III MA, VII MA type

Connecting your smartphone with the vehicle and a *Bluetooth*® headset via *Bluetooth*® allows you to operate the smartphone by voice input from the headset. You can also use the system by operating switches on the handlebar.

- ▶ To use the system, you need to install the dedicated application on your smartphone beforehand and pair your smartphone with the vehicle and the headset.

For terms of service and information on how to install/operate the dedicated application, see the following URL:

<https://global.honda/voice-control-system/>



- ▶ The dedicated application is not available in some regions/countries. For available countries, see the above URL.

Honda RoadSync *(Continued)*

Communication range:

Within 1 meters radius from vehicle

Supported *Bluetooth*[®] version/profiles

<i>Bluetooth</i> [®] version	Bluetooth 4.2 or higher
<i>Bluetooth</i> [®] profiles	GATT (Generic Attribute Profile)
	HOGP (HID over GATT Profile)

Bluetooth[®] Wireless Technology

The *Bluetooth*[®] word mark and logos are registered trademarks owned by Bluetooth SIG, Inc., and any use of such marks by Honda Motors Co., Ltd., is under license. Other trademarks and trade names are those of their respective owners.

- Costs of network communication and communication equipment necessary for the use of this feature shall be borne by the user.
- You cannot pair two or more smartphones at once.
- Some smartphones may not be compatible with the feature.
- We shall not be liable for any damages or trouble in the use of smartphones.
- When unable to connect your smartphone to the vehicle, change the storage location of the smartphone.

The system itself has certain limitations. Therefore, you must verify the voice guidance and information in the meter provided by the system by carefully observing the roadway, signs, and signals, etc. If you are unsure, proceed with caution. Always use your own good judgement, and obey traffic laws while riding.

⚠️ WARNING

Using Honda RoadSync while riding can take your attention away from the road, causing a crash in which you could be seriously injured or killed.

- Be especially cautious when crossing intersections, in heavy traffic, etc.
- Carefully observe the roadway, signs, and signals.
- Obey traffic laws while riding.

Honda RoadSync Limitations

Changes in operating systems, hardware, software, and other technology integral to providing Honda RoadSync functionality, as well as new or revised governmental regulations, may result in a decrease or cessation of Honda RoadSync functionality and services.

Honda cannot and does not provide any warranty or guarantee of future Honda RoadSync performance or functionality.





Honda RoadSync (Continued)

Pairing your smartphone via Bluetooth®

Make a Bluetooth® pairing after stopping at a safe place.

Only one smartphone can be connected at the same time.

To connect other smartphone, reset the Bluetooth® pairing record. **➡P.53**

- 1 Select the BLUETOOTH PAIRING RESET menu. **➡P.40** **➡P.53**
- 2 Press and hold the  on the sel  switch to select "YES." **➡P.53**
 - ▶ Press  of the  sel switch to cancel the pairing. The display returns to the upper level hierarchy.

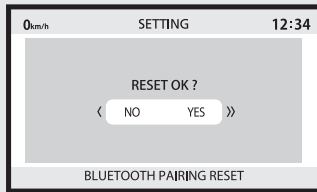

- 3 "PROCEEDING..." is displayed and the system will be in pairing standby. Perform the pairing operation by the application on your smartphone within about 2 minutes.

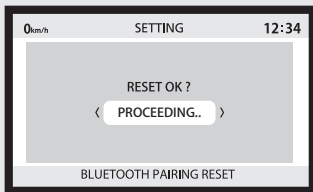

- On the ordinary display, the *Bluetooth*® indicator is flashing while waiting for pairing.

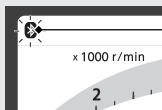

**Bluetooth®
indicator**

- For operation of the application, follow the instruction of the application.

- 4 When pairing is complete, "FINISHED" will be displayed.
- Even if it is not completed, "FINISHED" will be displayed about 2 minutes after. Check the status icons to confirm pairing is complete. ➔ P.25
- If pairing is not completed, perform 1 to 3 again.

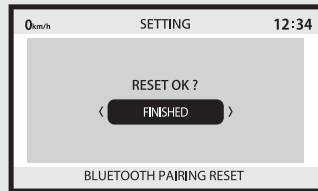



Idling Stop System

Idling Stop system is designed to help reduce the fuel consumption and noise, by idling stop while making a stop such as waiting at an intersection.

Switching the Idling Stop System On or Off

Switches the Idling Stop system on or off using the Idling Stop switch.

- ON:  **(Idling Stop)**
 - ▶ Idling Stop indicator comes on when the Idling Stop system becomes ready to stop the engine while riding. Idling Stop indicator flashes when the engine is stopped by the Idling Stop system.
- OFF:  **(Idling)**
 - ▶ Idling Stop indicator does not come on when the Idling Stop system is off.

Activation of the Idling Stop System

The Idling Stop system becomes ready to stop the engine and Idling Stop indicator comes on when the following requirements are satisfied with the Idling Stop switch in the

(A) (Idling Stop) position:

- side stand is up.
- start the engine by pressing the start button.
- warm up the engine enough.
- ride the vehicle at speeds over 10 km/h (6 mph).

Idling Stop Indicator Does Not Come

On:  **P.178**

Idling Stop switch

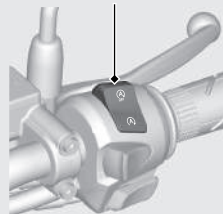

III MA, VII MA type

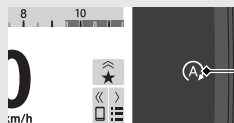

Idling Stop indicator

MA type

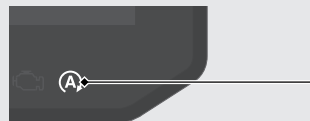

Idling Stop System *(Continued)*

Stopping the engine by the Idling Stop System

The engine stops and Idling Stop indicator changes to flash after you close the throttle completely and stop the vehicle while the Idling Stop indicator is on.

- ▶ While the engine is stopped by the Idling Stop system, if you press the Idling Stop switch to  (Idling), the Idling Stop system will be cancelled. The engine will not restart even when you open the throttle.

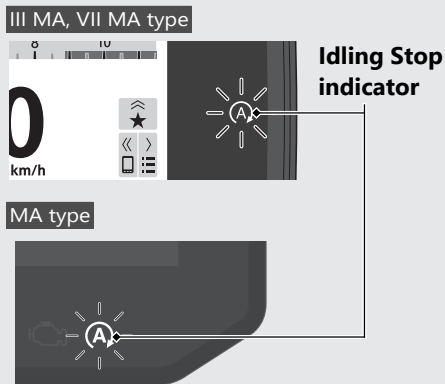

Safety Precaution for the Idling Stop System

Do not go away from the vehicle while the Idling Stop indicator is flashing. When you go away from the vehicle, always turn the ignition switch to the  (Off) position.

- ▶ The engine may start unexpectedly if the throttle is opened.

Engine is Not Stopped by the Idling Stop System While the Idling Stop Indicator is On:  **P.179**

NOTICE

Stopping by the Idling Stop system for a long time may cause battery discharge.

Idling Stop System *(Continued)*

Restarting the Engine

Check that the Idling Stop indicator is flashing, and then open the throttle.

- ▶ If it is not flashing, you can't restart the engine with the Idling Stop system, even if you open the throttle.
- ▶ While the engine is stopped by the Idling Stop system, if you operate the side stand, the flashing Idling Stop indicator turns off or stops flashing and stays on, then the engine will not restart even when you open the throttle.

Engine Does Not Start Even If the Throttle is Opened: ➡ P.180

NOTICE

Headlights stay on after the engine is stopped by the Idling Stop system. The battery may discharge and you may not be able to restart engine.

When the battery is weak, switch the Idling Stop switch to  (Idling) and do not to use the Idling Stop system. See your dealer to check the battery.

See your dealer for checking the battery as specified in the maintenance schedule.

Maintenance Schedule: ➡ P.139

Honda Selectable Torque Control

Torque Control (engine power control) can be turned on/off.

- ▶ Do not turn the Torque Control off or on while riding.
Stop the vehicle first, turn the Torque Control off or on.
- ▶ The Torque Control setting cannot be turned off when the system is activated (Torque Control indicator flashing).
- ▶ Each time the ignition switch is turned to the **I** (On) position, the Torque Control will automatically be set to on .

Torque Control on and off

MA type

Refer to "HSTC information". ➡ **P.67**

III MA, VII MA type

Torque Control can be turned on and off by pressing and holding the Torque Control switch.

Torque Control switch

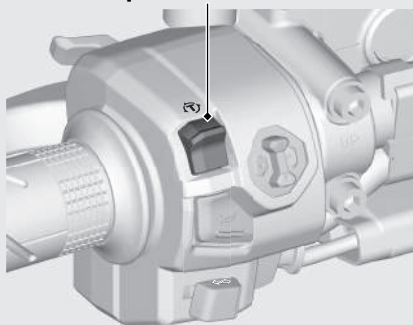

Starting the Engine

Start your engine using the following procedure, regardless of whether the engine is cold or warm.

This vehicle is equipped with a side stand ignition cut-off system.

- ▶ If the side stand is down, the engine cannot be started.
- ▶ If you lower the side stand with the engine running, it will automatically shut off.

This vehicle is equipped with a Honda SMART Key system. Always keep Honda SMART Key on you when you ride the vehicle.  **P.91**

If the engine is stopped while the ignition switch is in the **I** (On) position, authentication will be disabled after a certain amount of time or if you leave the authentication range. Restart the engine by performing the start procedure after pressing the ignition switch again.

- ▶ If the engine of this vehicle is stopped by the Idling Stop System, authentication will not be disabled.
- ▶ If the Honda SMART Key is within the authentication range and authentication is disabled after a certain amount of time, the Honda SMART Key indicator will notify you by flashing rapidly for a certain amount of time.

NOTICE

- If the engine does not start within 5 seconds, turn the ignition switch to the **O** (Off) position and wait 10 seconds before trying to start the engine again to recover battery voltage.
- Extended fast idling and revving the engine can damage the engine and the exhaust system.
- If the vehicle is over-turned, you must first turn the ignition switch to the **O** (Off) position and then inspect the vehicle carefully.

- 1 Place the vehicle on its centre stand.
- 2 Turn the ignition switch to the **I** (On) position.
 - ▶ To unlock the ignition switch. ➔ P.94

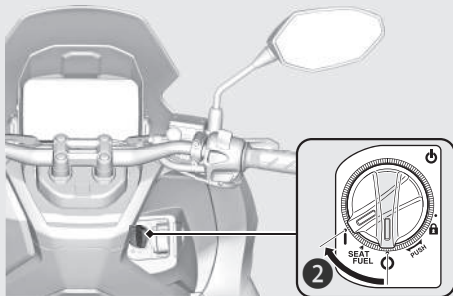

- 3 Squeeze the rear brake lever.
 - ▶ The starter motor will only work when the rear brake lever is squeezed and the side stand is up.
- 4 With the throttle completely closed, press the start button.

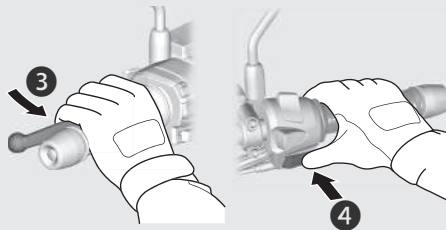

Starting the Engine *(Continued)*

If you cannot start the engine:

- ① Place the vehicle on its centre stand and squeeze the rear brake lever.
- ② Open the throttle slightly (about 3 mm, without freeplay), press the start button.

About 3 mm, without freeplay

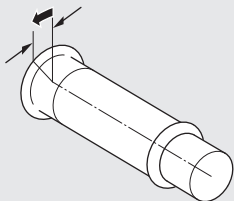

If the engine does not start:

- ① Open the throttle fully and press the start button for 5 seconds.
 - ▶ The engine will not start at this time. (When the throttle is fully open, the engine will not start when the start button is pressed.) Release the throttle and start button after 5 seconds and proceed to step ②.
- ② Repeat the normal starting procedure.
- ③ If the engine starts, open the throttle slightly if idling is unstable.
- ④ If the engine does not start, wait 10 seconds before trying steps ① & ② again.

If Engine Will Not Start ➔ P.168

Riding

Starting the Vehicle

- 1 Push the vehicle forward off the centre stand.
 - ▶ Squeeze the rear brake lever.
 - ▶ Keep throttle closed.

Make sure the side stand and centre stand are up.

- 2 Get on the vehicle.
 - ▶ Mount the vehicle from the left side, keeping at least one foot on the ground.
- 3 Release the brake lever.

- 4 Acceleration and deceleration
To accelerate: Open the throttle slowly.
To decelerate: Close the throttle.

Close (Decelerate) Open (Accelerate)

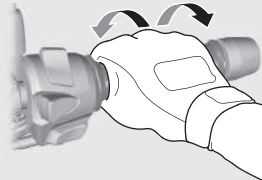

Riding *(Continued)*

Braking

Close the throttle and apply the front and rear brake levers together.

NOTICE

To prevent clutch damage, do not use the throttle to keep the vehicle stopped at up hill.

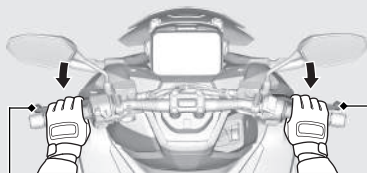

Rear brake lever

Front brake lever

Emergency Stop Signal

Emergency stop signal activates when the system detects hard braking about 50 km/h (31 mph) or above to alert drivers behind you about sudden braking by rapidly flashing both turn signal lights. This may help to alert drivers behind you to take appropriate means to avoid a possible collision with your vehicle.

The emergency stop signal stops operating when:

- You release the brakes.
- The ABS is deactivated.
- Your vehicle's decelerating speed becomes moderate.
- You press the hazard switch.

When the system activates:

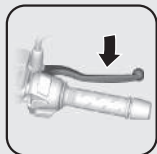

1 Hard braking

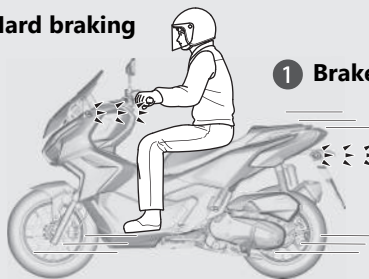
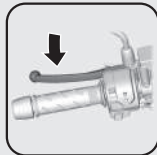

1 Brakelight comes on

2 Both turn signals flash

2 Both turn signal indicators blink

Emergency Stop Signal *(Continued)*

- ▶ The emergency stop signal is not a system that can prevent a possible rear-end collision caused by your hard braking. It is always recommended to avoid hard braking unless it is absolutely necessary.
- ▶ The emergency stop signal does not activate while the hazard switch is on.
- ▶ If the ABS stops working for a certain period during braking, the emergency stop signal may not activate at all.

Refuelling

Fuel type: Unleaded petrol only

Fuel octane number: Your vehicle is designed to use Research Octane Number (RON) 91 or higher.

Tank capacity: 8.1 L (2.14 US gal, 1.78 Imp gal)

Refuelling and Fuel Guidelines ➔ P.16

Opening the Fuel Fill Cap

- 1 Turn the ignition switch to the SEAT FUEL position.
 - ▶ To unlock the ignition switch ➔ P.94
- 2 Push the FUEL side of the fuel lid and seat opener switch.
 - ▶ The fuel lid opens.

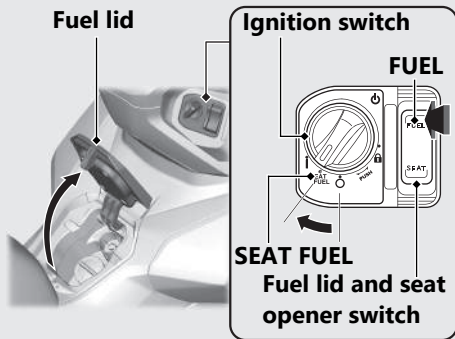

Refuelling *(Continued)*

- 3 Turn the fuel fill cap counterclockwise and remove the fuel fill cap.

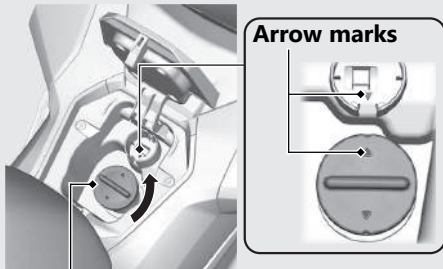

Fuel fill cap

- 4 Put the removed fuel fill cap on the fuel fill cap resting place.

Fuel fill cap resting place

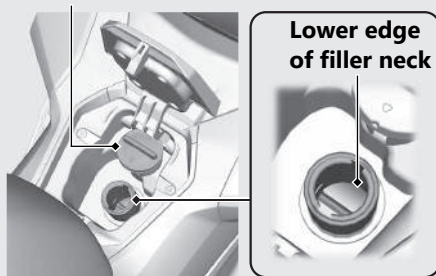

Do not fill with fuel above the lower edge of the filler neck.

Closing the Fuel Fill Cap

- ① Install and tighten the fuel fill cap firmly by turning it clockwise.
 - ▶ Make sure that the arrow marks on the fuel fill cap and fuel tank are aligned.
- ② Close the fuel lid until it locks.
 - ▶ Make sure that the fuel lid is closed securely.

WARNING

Petrol is highly flammable and explosive. You can be burned or seriously injured when handling fuel.

- Stop the engine, and keep heat, sparks, and flames away.
- Only handle fuel outdoors.
- Wipe up spills immediately.

USB Socket

Your vehicle is equipped with the USB socket (for USB Type-C only).

The USB socket is located in the front box.

➔ **P.136**

Use USB devices at your own risk. In no event shall Honda be liable for any damage to your USB device when in use.

Open the cover to access the socket.

Rated capacity :

15 W (5 V, 3.0 A)

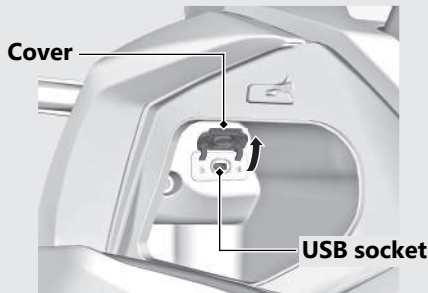

- ▶ To prevent the battery from becoming weak (or dead), keep the engine running while drawing current from the USB socket.
- ▶ Set the headlight on low beam while the USB socket is in use. The battery may run down or cause damage to the USB socket.
- ▶ To prevent entry of foreign matter into the USB socket, be sure to close the cover when the socket is not used.

NOTICE

- Using any heat-generating USB devices or improperly rated USB devices can damage the USB socket.
- Do not use the USB socket in wet conditions, when or while washing or any other wet conditions as these will damage the USB socket.

Storage Equipment

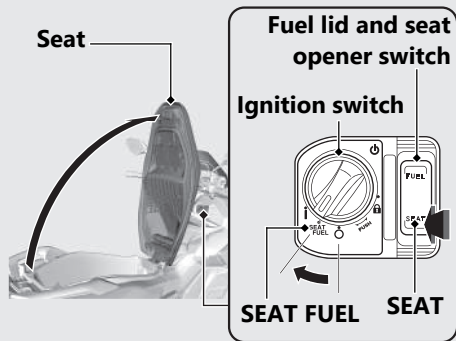

Seat Open

- 1 Turn the handlebar pointed straight ahead.
- 2 Turn the ignition switch to the SEAT FUEL position.
 - ▶ To unlock the ignition switch. **➔ P.94**
- 3 Push the SEAT side of the fuel lid and seat opener switch.
- 4 Open the seat.

Seat Close

Close and push down on the rear of the seat until it locks. Make sure that the seat is locked securely by pulling it up lightly. Take care not to lock your key in the compartment under the seat.

Storage Equipment *(Continued)*

Helmet Holder

The helmet holders are located under the seat.

- ▶ Use the helmet holder only when parked.

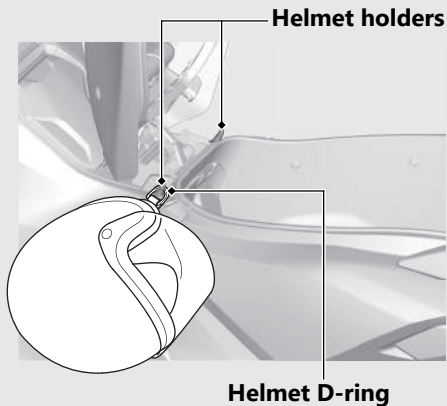

⚠ WARNING

Riding with a helmet attached to the holder can interfere with your ability to safely operate the vehicle and could lead to a crash in which you can be seriously hurt or killed.

Use the helmet holder only while parked. Do not ride with a helmet secured by the holder.

Centre Compartment

A helmet can be stored in the centre compartment.

Set in the front of the helmet forward.

- ▶ Some helmets may not fit in the compartment due to their size or design.

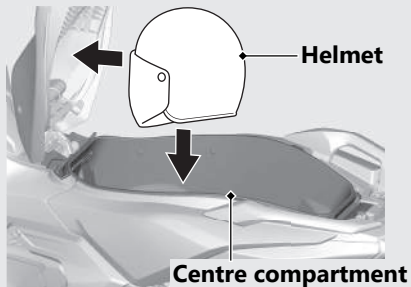

Never exceed the maximum weight limit.

Maximum Weight: 10 kg (22 lb)

- ▶ Do not store any items that are flammable or susceptible to heat damage.
- ▶ Do not store valuables or fragile articles.

Tool Kit/Document Bag

The tool kit and document bag are located underside of the seat by the rubber strap.

Document bag

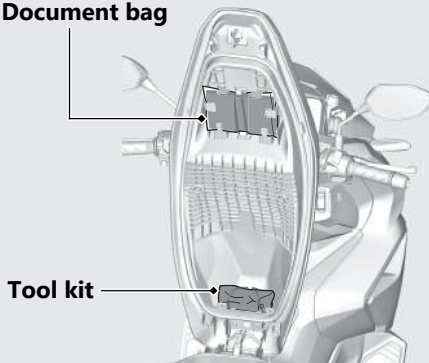

Storage Equipment *(Continued)*

Front Box

Open

Push the front box lid, then open the front box lid.

Close

Close the front box lid by pressing the front box lid.

The maximum allowable load in the front box shall be no more than

1 kg (2.2 lb)

Make sure that the front box lid is closed securely.

- ▶ Do not store valuables or fragile articles.

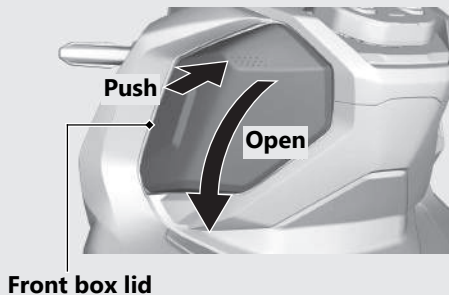

Maintenance

Please read "Importance of Maintenance" and "Maintenance Fundamentals" carefully before attempting any maintenance. Refer to "Specifications" for service data.

Importance of Maintenance	P. 138	Other Adjustments	P. 163
Maintenance Schedule	P. 139	Adjusting the Windscreen Height.....	P. 163
Maintenance Fundamentals	P. 142	Other Replacement	P. 164
Tools	P. 151	Replacing the Honda SMART Key Battery ..	P. 164
Removing & Installing Body			
Components	P. 152		
Battery.....	P. 152		
Battery Cover	P. 153		
Front Lid	P. 154		
Engine Oil	P. 155		
Coolant	P. 157		
Brakes	P. 159		
Side Stand	P. 161		
Throttle	P. 162		

Importance of Maintenance

Importance of Maintenance

Keeping your vehicle well-maintained is absolutely essential to your safety and to protect your investment, obtain maximum performance, avoid breakdowns, and reduce air pollution. Maintenance is the owner's responsibility. Be sure to inspect your vehicle before each ride and perform the periodic checks specified in the Maintenance Schedule.

➤ P. 139

⚠ WARNING

Improperly maintaining your vehicle or failing to correct a problem before you ride can cause a crash in which you can be seriously hurt or killed.

Always follow the inspection and maintenance recommendations and schedules in this owner's manual.

Maintenance Safety

Always read the maintenance instructions before you begin each task and make sure that you have the tools, parts, and skills required. We cannot warn you of every conceivable hazard that can arise in performing maintenance. Only you can decide whether or not you should perform a given task.

Follow these guidelines when performing maintenance.

- Stop the engine and turn the ignition switch to the **○** (Off) position.
- Place your vehicle on a firm, level surface using the side stand, centre stand or a maintenance stand to provide support.
- Allow the engine, muffler, brakes, and other high-temperature parts to cool before servicing as you can get burned.
- Run the engine only when instructed, and do so in a well-ventilated area.

Maintenance Schedule

The maintenance schedule specifies the maintenance requirements necessary to ensure safe, dependable performance and proper emission control.







Maintenance work should be performed in accordance with Honda's standards and specifications by properly trained and equipped technicians. Your dealer meets all of these requirements. Keep an accurate record of maintenance to help ensure that your vehicle is properly maintained.

Make sure that whomever performs the maintenance completes this record.

All scheduled maintenance is considered a normal owner operating cost and will be charged to you by your dealer. Retain all receipts. If you sell the vehicle, these receipts should be transferred with the vehicle to the new owner.

Honda recommends that your dealer should road test your vehicle after each periodic maintenance is carried out.

Maintenance Schedule

Items	Pre-ride Check P. 142	Frequency *1									Annual Check	Regular Replace	Refer to page	
		× 1,000 km	1	6	12	18	24	30	36					
		× 1,000 mi	0.6	4	8	12	16	20	24					
Fuel Line				I	I	I	I	I	I	I	I			-
Fuel Level		I												-
Throttle Operation		I		I	I	I	I	I	I	I	I			162
Air Cleaner *2						R				R				-
Crankcase Breather *3				C	C	C	C	C	C	C				-
Spark Plug				I	R	I	R	I	R					-
Valve Clearance				I	I	I	I	I	I	I				-
Engine Oil		I	R	R	R	R	R	R	R	R	R			155
Engine Oil Strainer Screen					C			C		C				-
Engine Idle Speed			I	I	I	I	I	I	I	I	I			-
Radiator Coolant *4		I						I		I	I	3 Years		157
Cooling System								I		I	I			-

Maintenance Level

 : Intermediate. We recommend service by your dealer, unless you have the necessary tools and are mechanically skilled.

Procedures are provided in an official Honda Shop Manual.









 : Technical. In the interest of safety, have your vehicle serviced by your dealer.

Maintenance Legend

I : Inspect (clean, adjust, lubricate, or replace, if necessary)

R : Replace

C : Clean

Items		Pre-ride Check P. 142	Frequency *1								Annual Check	Regular Replace	Refer to page		
			× 1,000 km	1	6	12	18	24	30	36					
			× 1,000 mi	0.6	4	8	12	16	20	24					
Drive Belt						I			R		I				-
Final Drive Oil *4														2 Years	-
Battery					I	I	I	I	I	I	I	I			152
Brake Fluid *4		I			I	I	I	I	I	I	I	I	2 Years	159	
Brake Pads Wear		I			I	I	I	I	I	I	I	I		160	
Brake System			I		I	I	I	I	I	I	I	I		142	
Headlight Aim					I	I	I	I	I	I	I	I		-	
Lights/Horn		I												-	
Clutch Shoes Wear							I		I		I			-	
Side Stand		I			I	I	I	I	I	I	I	I		161	
Suspension					I	I	I	I	I	I	I	I		-	
Nuts, Bolts, Fasteners			I			I			I		I	I		-	
Wheels/Tyres		I			I	I	I	I	I	I	I	I		148	
Steering Head Bearings						I			I		I	I		-	

Notes:

*1 : At higher odometer reading, repeat at the frequency interval established here.

*2 : Service more frequently when riding in unusually wet or dusty areas.

*3 : Service more frequently when riding in rain or at full throttle.

*4 : Replacement requires mechanical skill.

Pre-ride Inspection

To ensure safety, it is your responsibility to perform a pre-ride inspection and make sure that any problem you find is corrected. A pre-ride inspection is a must, not only for safety, but because having a breakdown, or even a flat tyre, can be a major inconvenience.

Check the following items before you get on your vehicle:

- Fuel level - Fill fuel tank when necessary. ➤ P. 129
- Throttle - Check for smooth opening and full closing in all steering positions. ➤ P. 162
- Engine oil level - Add engine oil if necessary. Check for leaks. ➤ P. 155
- Coolant level - Add coolant if required. Check for leaks. ➤ P. 157
- Brakes - Check operation;
Front and Rear: check brake fluid level and pads wear ➤ P. 159, ➤ P. 160
- Lights and horn - Check that lights, indicators and horn function properly.
- Side stand ignition cut-off system - Check for proper function. ➤ P. 161
- Wheels and tires - Check condition, air pressure and adjust if necessary. ➤ P. 148

Replacing Parts

Always use Honda Genuine Parts or their equivalents to ensure reliability and safety.

⚠WARNING

Installing non-Honda parts may make your vehicle unsafe and cause a crash in which you can be seriously hurt or killed.

Always use Honda Genuine Parts or equivalents that have been designed and approved for your vehicle.

Battery

Your vehicle has a maintenance-free type battery. You do not have to check the battery electrolyte level or add distilled water. Clean the battery terminals if they become dirty or corroded.

Do not remove the battery cap seals. There is no need to remove the cap when charging.

NOTICE

Your battery is a maintenance-free type and can be permanently damaged if the cap strip is removed.



This symbol on the battery means that this product must not be treated as household waste.

NOTICE

An improperly disposed of battery can be harmful to the environment and human health. Always confirm local regulations for proper battery disposal instruction.

What to do in an emergency

If any of the following occur, immediately see your doctor.

- Electrolyte splashes into your eyes:
 - ▶ Wash your eyes repeatedly with cool water for at least 15 minutes. Using water under pressure can damage your eyes.
- Electrolyte splashes onto your skin:
 - ▶ Remove affected clothing and wash your skin thoroughly using water.
- Electrolyte splashes into your mouth:
 - ▶ Rinse mouth thoroughly with water, and do not swallow.

WARNING

The battery gives off explosive hydrogen gas during normal operation.

A spark or flame can cause the battery to explode with enough force to kill or seriously hurt you.

Wear protective clothing and a face shield, or have a skilled mechanic do the battery servicing.

Cleaning the Battery Terminals

1. Remove the battery. ➤ P. 152
2. If the terminals are starting to corrode and are coated with a white substance, wash with warm water and wipe clean.

- If the terminals are heavily corroded, clean and polish the terminals with a wire brush or sandpaper. Wear safety glasses.

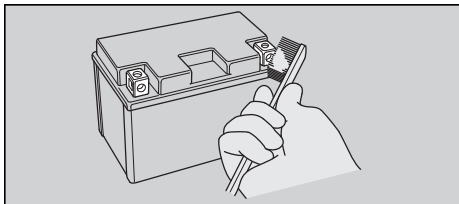

- After cleaning, reinstall the battery.

The battery has a limited life span. Consult your dealer about when you should replace the battery. Always replace the battery with another maintenance-free battery of the same type.

NOTICE

Installing non-Honda electrical accessories can overload the electrical system, discharging the battery and possibly damaging the system.

Fuses

Fuses protect the electrical circuits on your vehicle. If something electrical on your vehicle stops working, check for and replace any blown fuses. ➤ P. 191

Inspecting and Replacing Fuses

Turn the ignition switch to the **○** (Off) position to remove and inspect fuses. If a fuse is blown, replace with a fuse of the same rating. For fuse ratings, see "Specifications." ➤ P. 210

Blown fuse

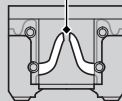

NOTICE

Replacing a fuse with one that has a higher rating greatly increases the chance of damage to the electrical system.

Maintenance Fundamentals

If a fuse fails repeatedly, you likely have an electrical fault. Have your vehicle inspected by your dealer.

Engine Oil

Engine oil consumption varies and oil quality deteriorates according to riding conditions and time elapsed.

Check the engine oil level regularly, and add the recommended engine oil if necessary. Dirty oil or old oil should be changed as soon as possible.

■ Selecting the Engine Oil

For recommended engine oil, see “Specifications.” P. 209

If you use non-Honda engine oil, check the label to make sure that the oil satisfies all of the following standards:

- JASO T 903 standard^{*1}: MB
- SAE standard^{*2}: 10W-30
- API classification^{*3}: SJ or higher

^{*1}. The JASO T 903 standard is an index for engine oils for 4-stroke motorcycle engines. There are two classes: MA and MB. For example, the following label shows the MB classification.

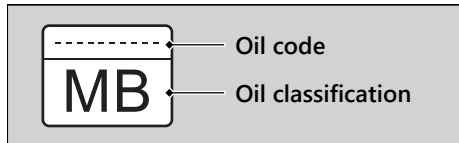

^{*2}. The SAE standard grades oils by their viscosity.

^{*3}. The API classification specifies the quality and performance rating of engine oils. Use SJ or higher oils, excluding oils marked as “Energy Conserving” or “Resource Conserving” on the circular API service symbol.

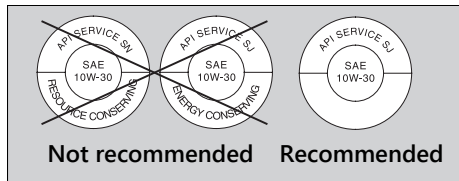

Brake Fluid

Do not add or replace brake fluid, except in an emergency. Use only fresh brake fluid from a sealed container. If you do add fluid, have the brake system serviced by your dealer as soon as possible.

NOTICE

Brake fluid can damage plastic and painted surfaces.
Wipe up spills immediately and wash thoroughly.

Recommended brake fluid:

Honda DOT 3 or DOT 4 Brake Fluid or equivalent

Recommended Coolant

Use only genuine HONDA PRE-MIX COOLANT without diluting with water. Genuine HONDA PRE-MIX COOLANT is excellent at preventing corrosion and overheating. The coolant should be inspected and replaced properly by following the maintenance schedule. ➤ P. 139

NOTICE

Using coolant not specified for aluminium engines or tap/mineral water can cause corrosion.

Crankcase Breathers

Service more frequently when riding in rain, at full throttle, or after the vehicle is washed or overturned. Service if the deposit level can be seen in the transparent section of the drain tube.

If the drain tube overflows, the air filter may become contaminated with engine oil, causing poor engine performance.

Tyres (Inspecting/Replacing)

Checking the Air Pressure

Visually inspect your tyres and use an air pressure gauge to measure the air pressure at least once a month or any time you think the tyres look low. Always check air pressure when your tyres are cold.

Inspecting for Damage

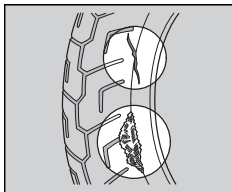

Inspect the tyres for cuts, slits, or cracks that expose fabric or cords, or nails or other foreign objects embedded in the side of the tyre or the tread.

Also inspect for any unusual bumps or bulges in the side walls of the tyres.

Inspecting for Abnormal Wear

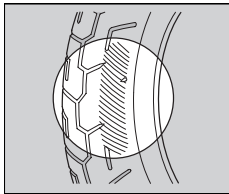

Inspect the tyres for signs of abnormal wear on the contact surface.

Inspecting Tread Depth

Inspect the tread wear indicators. If they become visible, replace the tyres immediately. For safe riding, you should replace the tyres when the minimum tread depth is reached.

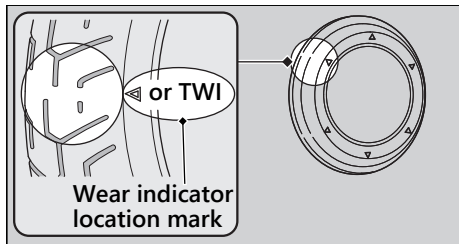

⚠️ WARNING

Riding on tyres that are excessively worn or improperly inflated can cause a crash in which you can be seriously hurt or killed.

Follow all instructions in this owner's manual regarding tyre inflation and maintenance.

Maintenance Fundamentals

Have your tyres replaced by your dealer. For recommended tyres, air pressure, and minimum tread depth, see "Specifications."

➤ P. 209

Follow these guidelines whenever you replace tyres:

- Use the recommended tyres or their equivalents of the same size, construction, speed rating, and load range.
- Do not install a tube inside a tubeless tyre on this vehicle. Excessive heat build-up can cause the tube to burst.
- Use only tubeless tyres on this vehicle. The rims are designed for tubeless tyres, and during hard acceleration or braking, a tube-type tyre could slip on the rim and cause the tyre to rapidly deflate.

WARNING

Installing improper tyres on your vehicle can adversely affect handling and stability, and can cause a crash in which you can be seriously hurt or killed.

Always use the size and type of tyres recommended in this owner's manual.

The tool kit is stored underside of the seat.

➔ P. 135

You can perform some roadside repairs, minor adjustments and parts replacement with the provided tools.

- Spark plug wrench
- 10 × 14 mm Open end wrench
- Standard/Phillips screwdriver
- Screwdriver handle

Battery

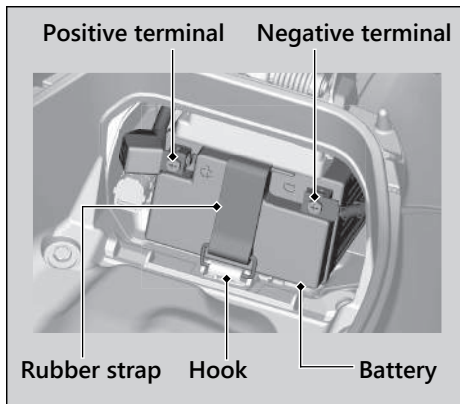

Removal

Make sure the ignition switch is in the \bigcirc (Off) position.

1. Remove the battery cover. ➤ P. 153
2. Remove the rubber strap from the hook.
3. Disconnect the negative \ominus terminal from the battery.
4. Disconnect the positive \oplus terminal from the battery.
5. Remove the battery, taking care not to drop the terminal nuts.

Installation

Install the parts in the reverse order of removal. Always connect the positive (+) terminal first. Make sure bolts and nuts are tight.

Make sure the clock information is correct after the battery is reconnected. ➤ P. 50

The anti-theft alarm system will be deactivated if the battery is disconnected. The system will remain off when the battery is reconnected.

To activate the system, see "Setting the Anti-theft Alarm System." ➤ P. 100

For proper handling of the battery, see "Maintenance Fundamentals." ➤ P. 143
"Battery Goes Dead." ➤ P. 190

Battery Cover

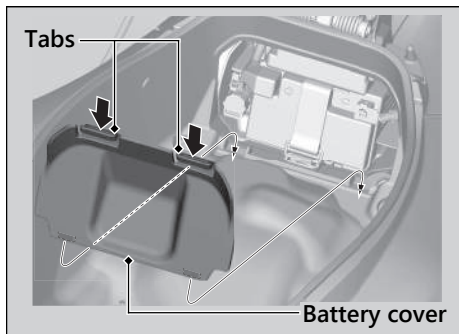

Removal

1. Open the seat. ➤ P. 133
2. Press the tabs and remove the battery cover.

Installation

Install the parts in the reverse order of removal.

Front Lid

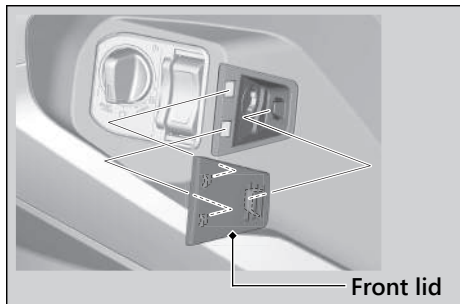

■ Removal

Pull out the front lid backward while pushing the side of the front lid.

■ Installation

Install the part in the reverse order of removal.

Make sure that all tabs are installed securely in position.

Checking the Engine Oil

Check the engine oil with the Idling Stop switch at  (Idling).

1. If the engine is cold, idle the engine for 3 to 5 minutes.
2. Turn the ignition switch to the  (Off) position and wait for 2 to 3 minutes.
3. Place your vehicle on its centre stand on a firm, level surface.
4. Remove the oil fill cap/dipstick and wipe it clean.
5. Insert the oil fill cap/dipstick until it seats, but don't screw it in.
6. Check that the oil level is between the upper level and lower level marks on the oil fill cap/dipstick.
7. Securely install the oil fill cap/dipstick.

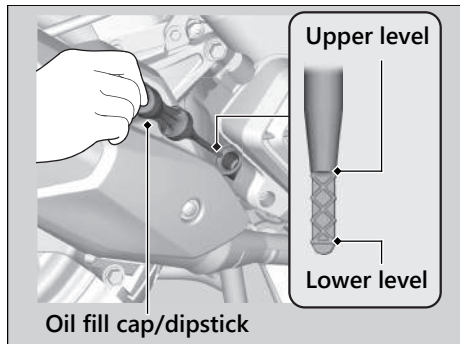

Adding Engine Oil

If the engine oil is below or near the lower level mark, add the recommended engine oil.

► P. 146, ► P. 209

1. Remove the oil fill cap/dipstick. Add the recommended oil until it reaches the upper level mark.
 - Place your vehicle on its centre stand on a firm, level surface when checking the oil level.
 - Do not overfill above the upper level mark.
 - Make sure no foreign objects enter the oil filler opening.
 - Wipe up any spills immediately.
2. Securely reinstall the oil fill cap/dipstick.

NOTICE

Overfilling with oil or operating with insufficient oil can cause damage to your engine. Do not mix different brands and grades of oil.

For the recommended oil and oil selection guidelines, see “Maintenance Fundamentals.”

► P. 146

Checking the Coolant

Check the coolant level in the reserve tank while the engine is cold.

1. Place your vehicle on its centre stand on a firm, level surface.
2. Check that the coolant level is between the UPPER level and LOWER level marks on the reserve tank.

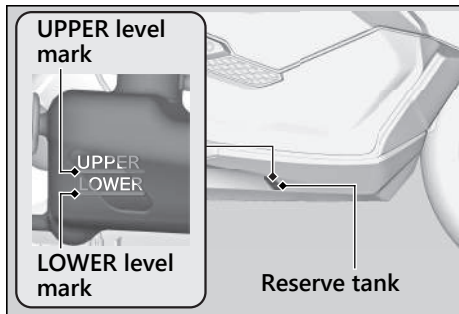

If the coolant level is dropping noticeably or the reserve tank is empty, you likely have a serious leak. Have your vehicle inspected by your dealer.

Adding Coolant

If the coolant level is below the LOWER level mark, add the recommended coolant (► P. 147) until the level reaches the UPPER level mark.

Add fluid only from the reserve tank cap and do not remove the radiator cap.

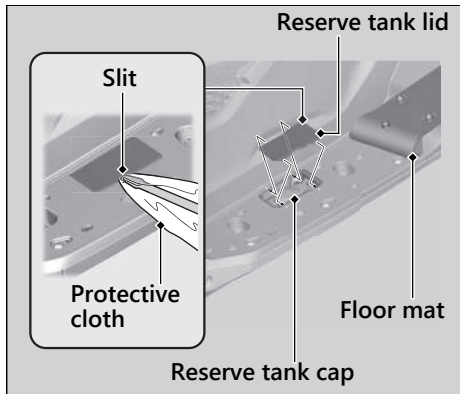

1. Pull the floor mat off.
2. Remove the reserve tank lid by inserting a flat head screwdriver covered with a protective cloth into the slit on the right side floor.
3. Remove the reserve tank cap and add fluid while monitoring the coolant level.
 - Do not overfill above the UPPER level mark.
 - Make sure no foreign objects enter the reserve tank opening.
4. Securely reinstall the reserve tank cap.
5. Install the reserve tank lid and floor mat.

⚠ WARNING

Removing the radiator cap while the engine is hot can cause the coolant to spray out, potentially scalding you.

Always let the engine and radiator cool down before removing the radiator cap.

Checking Brake Fluid

1. Place your vehicle in an upright position on a firm, level surface.
2. Check that the brake fluid reservoir is horizontal and that the fluid level is above the LWR level mark.

If the brake fluid level in either reservoir is below the LWR level mark or both the brake levers freeplay becomes excessive, inspect the brake pads for wear.

If the brake pads are not worn, you most likely have a leak. Have your vehicle inspected by your dealer.

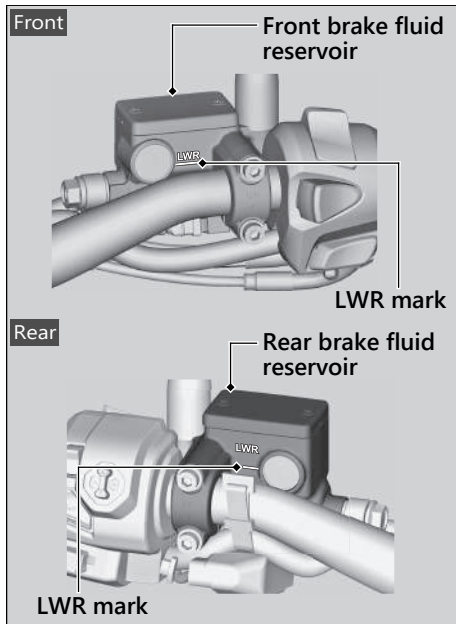

Inspecting the Brake Pads

Check the condition of the brake pad wear indicators.

The pads need to be replaced if a brake pad is worn to the indicator.

1. **Front** Inspect the brake pads from in front of the brake caliper.
2. **Rear** Inspect the brake pads from the rear right of the vehicle.

If necessary, have the pads replaced by your dealer.

Always replace both left and right brake pads at the same time.

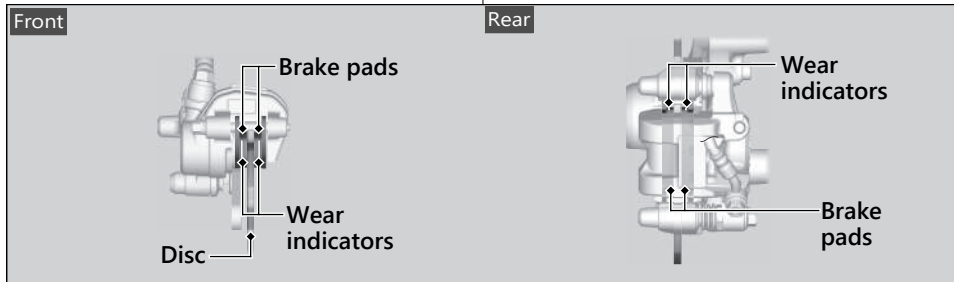

Checking the Side Stand

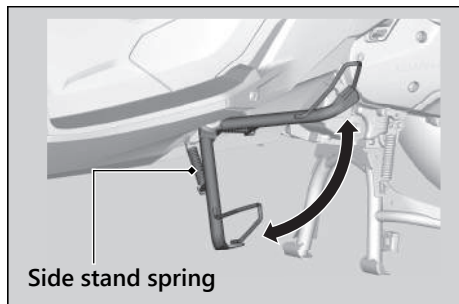

1. Place your vehicle on its centre stand on a firm, level surface.
2. Check that the side stand operates smoothly. If the side stand is stiff or squeaky, clean the pivot area and lubricate the pivot bolt with clean grease.
3. Check the spring for damage or loss of tension.
4. Sit on the vehicle and raise the side stand.
5. Start the engine.
6. Lower the side stand all the way. The engine should stop as you lower the side stand. If the engine doesn't stop, have your vehicle inspected by your dealer.

Checking the Throttle

With the engine off, check that the throttle rotates smoothly from fully closed to fully open in all steering positions and throttle freeplay is correct. If the throttle does not move smoothly or close automatically, or if the cable is damaged, have the vehicle inspected by your dealer.

Freeplay at the throttle grip flange:

2 - 6 mm (0.1 - 0.2 in)

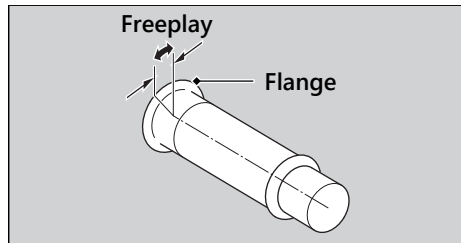

Adjusting the Windscreen Height

The windscreen can be adjusted to 2 positions.

- ▶ Do not adjust the windscreen while riding.

Pull the windscreen adjusting knobs and move the windscreen up or down.

- ▶ Make sure the windscreen is locked securely by slightly moving the windscreen up or down.

If the windscreen does not move smoothly, have your vehicle inspected by your dealer.

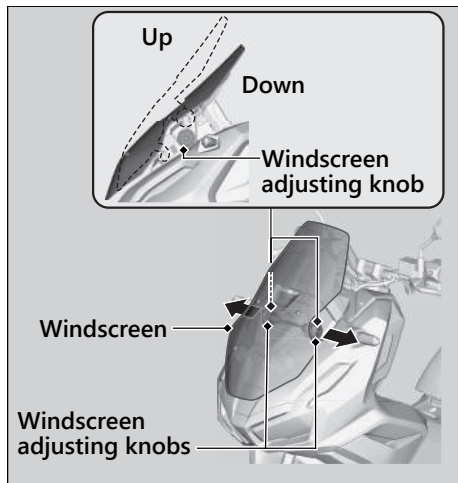

Replacing the Honda SMART Key Battery

If the Honda SMART Key indicator flashes 5 times when the ignition switch is turned **I** (On), or the operating range becomes unstable, replace the battery as soon as possible.

We recommend to see your dealer for this service.

Battery type: CR2032 or CR2032H

1. Remove the upper case by inserting a coin or a flat head screwdriver covered with a protective cloth into the slit.
 - ▶ Wrap a coin or a screwdriver with a protective cloth to prevent scratching the Honda SMART Key.
 - ▶ Do not touch the circuit or terminal. This may cause problems.
 - ▶ Be careful to avoid scratching the waterproof covering or allowing dust to enter.
 - ▶ Do not forcibly dismantle the Honda SMART Key body.

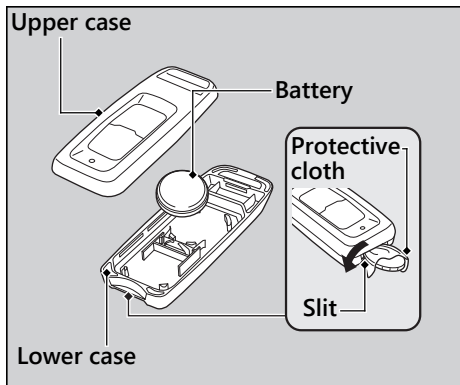

2. Replace the old battery with a new battery with the negative \ominus side facing up.
3. Snap the two halves of the remote transmitter back together.
 - Make sure that upper and lower cases are set in the right position.

⚠ WARNING

CHEMICAL BURN HAZARD

The battery that powers the Honda SMART Key can cause severe internal burns and can even lead to death if swallowed.

Keep new and used batteries away from children.

If you suspect that a child has swallowed the battery, seek medical attention immediately.

CAUTION

- Danger of explosion if battery is incorrectly replaced. Replace only with the same or equivalent type.
- Do not expose to excessive heat such as sunshine, fire or the like, that can result in an explosion or the leakage of flammable liquid or gas during use, storage or transportation.
- Do not dispose of a battery into fire or a hot oven, or give mechanically crushing or cutting of a battery, that can result in an explosion.
- Do not subject to extremely low air pressure at high altitude that may result in an explosion or the leakage of flammable liquid or gas.

Troubleshooting

Engine Will Not Start	P. 168
Overheating (High coolant temperature indicator is on)	P. 169
Warning Indicators On or Flashing	P. 170
PGM-FI (Programmed Fuel Injection) Malfunction Indicator Lamp (MIL)	P. 170
Battery Charging Condition indicator	P. 170
ABS (Anti-lock Brake System) Indicator	P. 171
Torque Control Indicator	P. 172
Honda SMART Key Indicator	P. 173
Other Warning Indications	P. 175
Fuel Gauge Failure Indication	P. 175
Coolant Temperature Gauge Failure Indication..	P. 177
When the Idling Stop System Does Not Operate Properly	P. 178
Idling Stop Indicator Does Not Come On	P. 178
Engine is Not Stopped by the Idling Stop System While the Idling Stop Indicator is On.....	P. 179
Engine Does Not Start Even If the Throttle is Opened	P. 180
When the Honda SMART Key System Does Not Operate Properly	P. 181
Unlock the Seat in an Emergency	P. 183
Unlock the Ignition Switch in an Emergency	P. 184
Tyre Puncture	P. 187
Smartphone Pairing Trouble	P. 188
Electrical Trouble	P. 190
Battery Goes Dead	P. 190
Burned-out Light Bulb.....	P. 190
Blown Fuse	P. 191
Unstable Engine Operation Occurs Intermittently	P. 192

Starter Motor Operates But Engine Does Not Start

Check the following items:

- Check the correct engine starting sequence. ➔ P. 122
- Check that there is petrol in the fuel tank.
- Check if the PGM-FI malfunction indicator lamp (MIL) is on.
 - ▶ If the indicator lamp is on, contact your dealer as soon as possible.

Starter Motor Does Not Operate

Check the following items:

- Check the correct engine starting sequence. ➔ P. 122
- Check for a blown fuse. ➔ P. 191
- Check for a loose battery connection (➔ P. 152) or battery terminal corrosion (➔ P. 143).
- Check the condition of the battery.
 - ➔ P. 190
- Check the Honda SMART Key indicator.
 - ▶ If it is flashing, start the engine by the normal procedure after pressing the ignition switch again. ➔ P. 122

If the problem continues, have your vehicle inspected by your dealer.

Overheating (High coolant temperature indicator is on)

The engine is overheating when the following occurs:

- **MA type**

High coolant temperature indicator comes on.

- **III MA, VII MA type**

High coolant temperature indicator and warning indicator come on.

Also the 8 th (H) segment flashes in the coolant temperature gauge. ➔ P. 57

- Acceleration becomes sluggish.

If this occurs, pull safely to the side of the road and perform the following procedure. Extended fast idling may cause the high coolant temperature indicator to come on.

NOTICE

Continuing to ride with an overheated engine can cause serious damage to the engine.

1. Stop the engine using the ignition switch.
2. Allow the engine to cool with the ignition switch in the  (Off) position.
3. After the engine has cooled, inspect the radiator hose and check if there is a leak.

➔ P. 157

If there is a leak:

Do not start the engine. Transport your vehicle to your dealer.

4. Check the coolant level in the reserve tank. ➔ P. 157
▶ Add coolant as necessary.

5. **MA type**

If 1-4 check normal, you may continue riding, but closely monitor the high coolant temperature indicator.

III MA, VII MA type

If 1-4 check normal, you may continue riding, but closely monitor the temperature gauge.

PGM-FI (Programmed Fuel Injection) Malfunction Indicator Lamp (MIL)

If the indicator comes on while riding, you may have a serious problem with the PGM-FI system. Reduce speed and have your vehicle inspected by your dealer as soon as possible.

Battery Charging Condition indicator

If the indicator comes on while riding, you may have a condition of low battery voltage or battery performance degradation. Have your vehicle inspected by your dealer.

- ▶ If the battery does not have enough voltage to drive the indicator system, the indicator may not come on.

ABS (Anti-lock Brake System) Indicator

If the indicator operates in one of the following ways, you may have a serious problem with the ABS. Reduce your speed and have your vehicle inspected by your dealer as soon as possible.

- Indicator comes on or starts flashing while riding.
- Indicator does not come on when the ignition switch is in the **I** (On) position.
- Indicator does not go off at speeds above 10 km/h (6 mph).

If the ABS indicator stays on, your brakes will continue to work as a conventional system, but without the anti-locking function.

The ABS indicator may flash if you turn the rear wheel while the rear wheel is lifted off the ground. In this case, turn the ignition switch to the **O** (Off) position, and then to the **I** (On) position again. The ABS indicator will go off after your speed reaches 30 km/h (19 mph).

Torque Control Indicator

If the indicator operates in one of the following ways, you may have a serious problem with the Torque Control. Reduce your speed and have your vehicle inspected by your dealer as soon as possible.

- Indicator comes and stays on (solid) while riding.
- Indicator does not come on when the ignition switch is turned to the **I** (On) position.
- Indicator does not go off at speeds above 3 km/h (2 mph).

Even when the Torque Control indicator is on, your vehicle will have normal riding ability without Torque Control function.

- When the indicator comes on while the Torque Control is in operation, you will have to completely close the throttle to regain normal riding ability.

The Torque Control indicator may come on if you rotate the rear wheel while your vehicle is lifted off the ground. In this case, turn the ignition switch to the **O** (Off) position, and then to the **I** (On) position again. The Torque Control indicator will go off after your speed reaches 3 km/h (2 mph).

Honda SMART Key Indicator

■ When the Honda SMART Key indicator flashes 5 times

Replacing the Honda SMART Key Battery ➤ P. 164

■ If the Honda SMART Key indicator is flashing rapidly while the ignition switch is in the **■ (On)** position

Start the engine by the normal procedure after pressing the ignition switch again.

➤ P. 122

■ When the Honda SMART Key indicator is flashing while the ignition switch is in the **■ (On)** position

The Honda SMART Key indicator flashes when communication between your vehicle and Honda SMART Key stops after turning the ignition switch to the **■ (On)** position. It is probably caused by the following:

- Strong radio waves or noise are affecting the system.
- You lose the Honda SMART Key while riding.

However, this does not affect the operation of your vehicle until the ignition switch is locked.

Warning Indicators On or Flashing ► Honda SMART Key Indicator

If you turn the ignition switch to the SEAT FUEL, ○ (Off) or 🔒 (Lock) position while the Honda SMART Key indicator is flashing, the ignition switch ring, Honda SMART Key indicator will flash faster, the buzzer will ring for about 20 seconds, automatically go off, and then the ignition switch will lock.

► Turn signals blink at the beginning and end of this function.

To stop this flashing and ringing, press and hold the ignition switch for more than 2 seconds. After the flashing and ringing stop, the ignition switch is locked.

If you do not have the Honda SMART Key, the ignition switch can be unlocked in another way. ➡ P. 184

Other Warning Indications

Fuel Gauge Failure Indication

If the fuel system has an error, the fuel gauge indicators will be displayed as shown in the illustrations.

If this occurs, see your dealer as soon as possible.

III MA, VII MA type

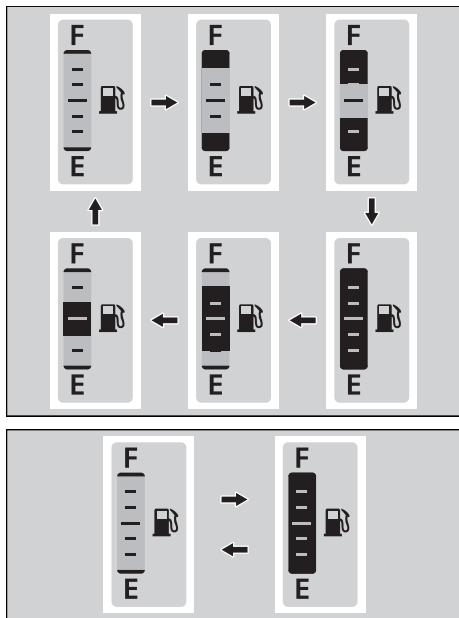
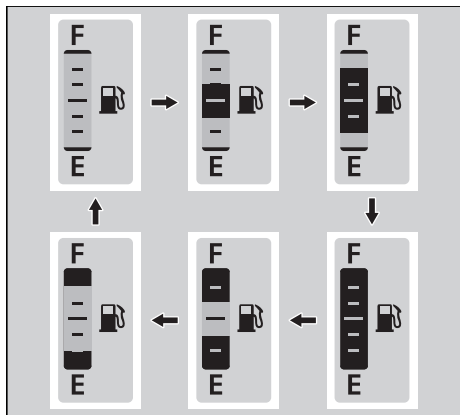

Other Warning Indications ▶ Fuel Gauge Failure Indication

MA type

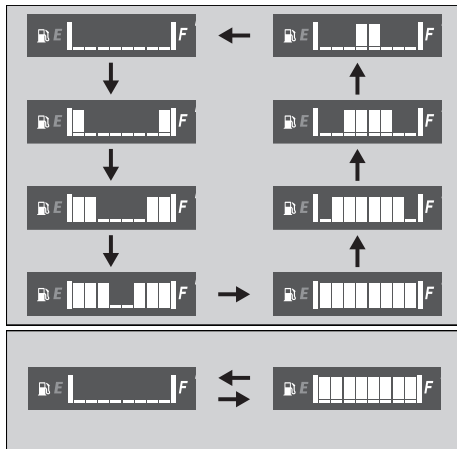
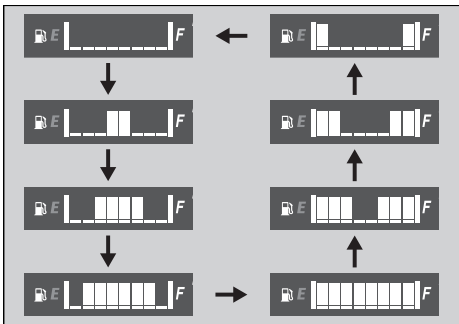

Coolant Temperature Gauge Failure Indication

III MA, VII MA type

If the cooling system has an error, all segments will blink as shown in the illustration.

If this occurs, see your dealer as soon as possible.

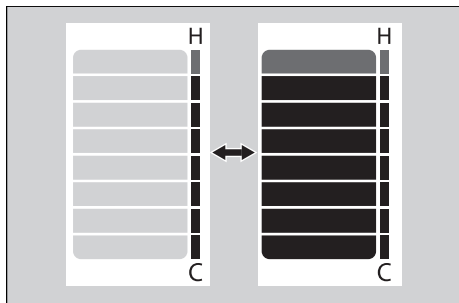

When the Idling Stop System Does Not Operate Properly

Idling Stop Indicator Does Not Come On

When the Idling Stop indicator does not come on, perform the followings.

If the Idling Stop switch is at  (Idling):

Press the Idling Stop switch to  (Idling Stop).

If the engine is cold:

Warm up the engine.

The Idling Stop system does not operate when the engine is cold.

If you did not ride the vehicle after engine starts:

Ride the vehicle at speeds of over 10 km/h (6 mph). The Idling Stop system does not operate until you ride once.

If PGM-FI malfunction indicator lamp (MIL) lights:

When the PGM-FI malfunction indicator lamp (MIL) lights, the Idling Stop system does not operate for protection of the engine. See your dealer.

If the battery voltage is low:

Ride the vehicle awhile, then stop the engine and then restart the engine with start button referring to the starting procedure ( P. 122) for standard engine starting. The Idling Stop system may not operate if the battery voltage is low.

If this occurs frequently, contact your dealer.

Engine is Not Stopped by the Idling Stop System While the Idling Stop Indicator is On

When the engine is not stopped by the Idling Stop system while the Idling Stop indicator is on, perform the followings.

If the vehicle does not stop completely:

Stop the vehicle completely. The Idling Stop system operates if the speed is only at 0 km/h (0 mph).

If the throttle is not closed completely:

Close the throttle completely.

Engine Does Not Start Even If the Throttle is Opened

Engine does not start even if the throttle is opened, perform the followings.

If the side stand is down:

While the engine is stopped by the Idling Stop system, if you operate the side stand, the flashing Idling Stop indicator turns off or stops flashing and stays on, and the Idling Stop system is cancelled. Restart the engine with start button referring to the starting procedure (▶ P. 122) for standard engine starting.

If the Idling Stop switch is at (Idling):

While the engine is stopping by the Idling Stop system, if you press the Idling Stop switch to  (Idling), the Idling Stop system will be cancelled. Restart the engine with start button referring to the starting procedure (▶ P. 122) for standard engine starting.

If the Idling Stop indicator flashes (the Idling Stop switch is at  (Idling Stop) position), but engine does not start even if the throttle is opened, perform the followings.

Low (or dead) battery or battery lead is loose:

Check the battery and battery terminals. If the battery is weak, contact your dealer.

When the Honda SMART Key System Does Not Operate Properly

When the Honda SMART Key system does not work properly, perform the following.

- Check that the Honda SMART Key system is activated.

Lightly push the ON/OFF button on the Honda SMART Key.

If the Honda SMART Key LED is red, activate the Honda SMART Key system.

➤ P. 90

If the Honda SMART Key LED does not respond, replace the battery.

- Check that there is no communication failure in the Honda SMART Key system. The Honda SMART Key system uses low-intensity radio waves. The Honda SMART Key system may not work properly in the following conditions:
 - ▶ When there are facilities nearby that generate strong radio waves or noise such as TV towers, power stations, radio stations, or airports.
 - ▶ When you carry the Honda SMART Key with a laptop or wireless communication device such as a radio or mobile phone.
 - ▶ When the Honda SMART Key comes into contact with or is covered by metal objects.

When the Honda SMART Key System Does Not Operate Properly

- Check that a registered Honda SMART Key is used.
Use a registered Honda SMART Key. The Honda SMART Key system cannot be activated without a registered Honda SMART Key.
- Make sure that you do not use a broken Honda SMART Key.
If you use a broken Honda SMART Key, the Honda SMART Key system cannot be activated. Bring the emergency key and ID tag to your dealer.

- Check the battery condition and battery lead in your vehicle.
Check the battery and battery terminals. If the battery is weak, contact your dealer.

If the Honda SMART Key system cannot be activated due to other causes, contact your dealer.

Unlock the Seat in an Emergency

The seat lock can be unlocked by using the emergency key.

Open

1. Remove the front lid. ➤ P. 154
2. Align the projection of the emergency key with the slot of the emergency seat opener, and turn the emergency key counterclockwise.
3. Open the seat.

Close

1. Close and push down on the rear of the seat until it locks. Make sure that the seat is locked securely by pulling it up lightly. If the seat is not locked, turn the emergency key clockwise to lock the seat catch.
2. Install the front lid.

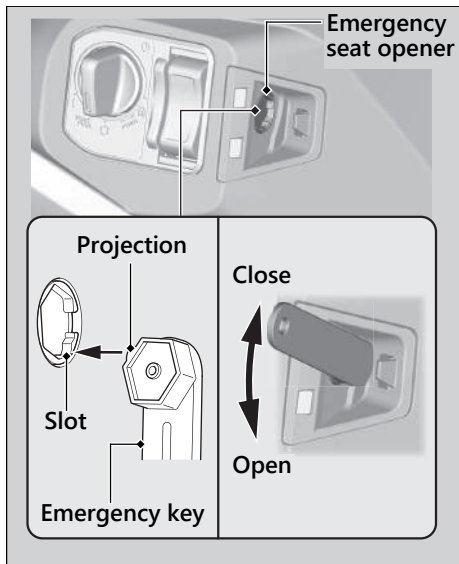



Unlock the Ignition Switch in an Emergency

Set up to ID number input mode

1. Check the ID number on the ID tag.
2. Press and hold the ignition switch for more than 4 seconds.
 - ▶ The ignition switch ring and the Honda SMART Key indicator blink.
3. Press the ignition switch while the ignition switch ring and the Honda SMART Key indicator are blinking.
 - ▶ The ignition switch ring and the Honda SMART Key indicator stay lit, and the ID number input mode turns on.



ID number input

You can input your ID number by pressing the ignition switch when the ignition switch is  (Off),  (Lock) and SEAT FUEL position. Input the ID number on the ID tag in order from the left in turn by pressing the ignition switch.

The ID number is authenticated according to the number of times the ignition switch is pushed.

Push the ignition switch the desired number of times within 5 seconds when the ignition switch ring comes on. After 5 seconds, the ignition switch ring goes off and comes on again. This means that the inputted number is fixed, and you can input the next number.

- ▶ If the ignition switch ring does not come on in blue, the battery may be low. Contact your dealer.

Example:

- To input "0", wait for 5 seconds without pushing the ignition switch when the ignition switch ring comes on.
- To input "1", push the ignition switch once within 5 seconds when the ignition switch ring comes on.

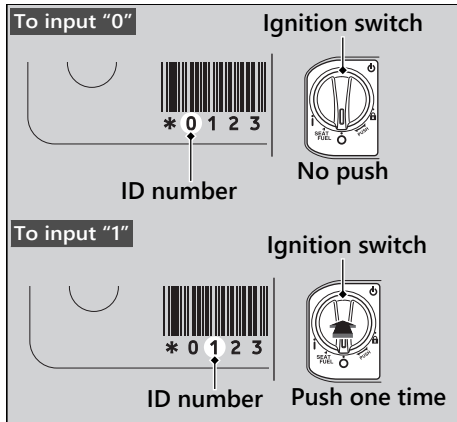

ID number input success

After the last ID number is input, the ignition switch ring and the Honda SMART Key indicator go off, and when they come on again the ignition switch is unlocked.

Turn the ignition switch to the **I** (On) position within 6 minutes. You can start the engine.

To lock the ignition switch, turn the ignition switch to the SEAT FUEL, **O** (Off), or **L** (Lock) position, and press and hold the ignition switch for 2 seconds. The ignition switch also locks automatically when the ignition switch has been in the SEAT FUEL, **O** (Off), or **L** (Lock) position for about 6 minutes after the ID number is successfully inputted.

When the ignition switch is locked, the ignition switch ring goes off.

To unlock the ignition switch again, repeat the procedure for unlocking the ignition switch.

Unlock the Ignition Switch in an Emergency

ID number input failure

After the last ID number is input, the ignition switch ring and the Honda SMART Key indicator blink at 1 second intervals, and then go off.

The ignition switch does not unlock.

Redo the "Unlock the Ignition Switch in an Emergency" procedure. ➤ P. 184

ID number input cancel

If you make a mistake while inputting your ID, do one of the following:

- Press and hold the ignition switch until the buzzer rings once, the ignition switch ring and the Honda SMART Key indicator to turn off.
- Do not press the ignition switch, just wait for the ignition switch ring and the Honda SMART Key indicator to turn off.

Redo the "Unlock the Ignition Switch in an Emergency" procedure. ➤ P. 184

Tyre Puncture

Repairing a puncture or removing a wheel requires special tools and technical expertise. We recommend you have this type of service performed by your dealer.

After an emergency repair, always have the tyre inspected/replaced by your dealer.

Emergency Repair Using a Tyre Repair Kit

If your tyre has a minor puncture, you can make an emergency repair using a tubeless tyre repair kit.

Follow the instructions provided with the emergency tyre repair kit.

Riding your vehicle with a temporary tyre repair is very risky. Do not exceed 50 km/h (30 mph). Have the tyre replaced by your dealer as soon as possible.

WARNING

Riding your vehicle with a temporary tyre repair can be risky. If the temporary repair fails, you can crash and be seriously injured or killed.

If you must ride with a temporary tyre repair, ride slowly and carefully and do not exceed 50 km/h (30 mph) until the tyre is replaced.

Smartphone Pairing Trouble

III MA, VII MA type

Symptom	Cause/remedy
Unable to pair a smartphone	Some smartphones you use may be incompatible with the vehicle and/or the operable functions may be limited.
	Check that the vehicle and smartphone are both in pairing mode. ➤ P. 114
	Check your surroundings to make sure no other device being paired is present before re-pairing. Presence of a <i>Bluetooth</i> [®] device in the vicinity sometimes affects the pairing due to radio wave interference, etc.
	When connecting a smartphone, make sure no other <i>Bluetooth</i> [®] device readied for pairing is present. Presence of a <i>Bluetooth</i> [®] device in the vicinity sometimes affects the pairing due to radio wave interference, etc.
	Check that the vehicle pairing information is deleted from your smartphone <i>Bluetooth</i> [®] setting. Depending on the smartphone used, connecting may not be possible unless the pairing information is deleted.

Symptom	Cause/remedy
Unable to connect a smartphone	Depending on the smartphone you use, it may take some time for the vehicle to connect to a smartphone and to start using a dedicated application.
	The connection may be temporarily disconnected when starting the engine, which is normal and not a malfunction. The smartphone will be reconnected after the engine is started.
	Check that <i>Bluetooth</i> [®] status icon comes on. Refer to the instruction manual of your smartphone and check that your smartphone is in connectable state.
	Some smartphones you use may not connect automatically. For connecting, follow the instructions in the instruction manual of your smartphone.
	You cannot connect two or more smartphones at once.

If the problem continues after the above-described inspection, have your vehicle inspected by your dealer.

Battery Goes Dead

Charge the battery using a motorcycle battery charger.

Remove the battery from the vehicle before charging.

Do not use an automobile-type battery charger, as these can overheat a motorcycle battery and cause permanent damage. If the battery does not recover after recharging, contact your dealer.

NOTICE

Jump starting using an automobile battery can damage your vehicle's electrical system and is not recommended.

Burned-out Light Bulb

All light bulbs on the vehicle are LEDs. If there is an LED which is not turned on, see your dealer for servicing.

Blown Fuse

Before handling fuses, see "Inspecting and Replacing Fuses." ► P. 145

Fuse Box Fuses

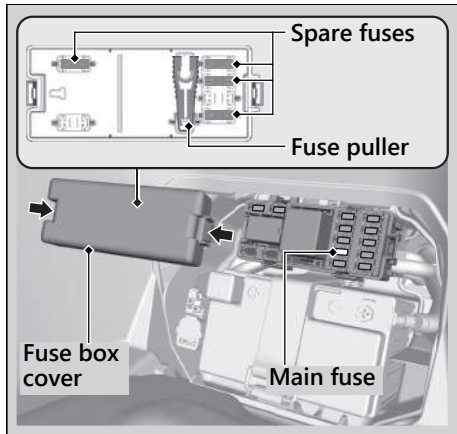

1. Remove the battery cover. ► P. 153
2. Open the fuse box cover.
3. Pull the main fuse and other fuses out one by one with the fuse puller located inside of the fuse box cover. Check for a blown fuse. Always replace a blown fuse with a spare fuse of the same rating.
4. Install the fuse box cover.
5. Install the battery cover.

NOTICE

If a fuse fails repeatedly, you likely have an electrical problem. Have your vehicle inspected by your dealer.

Unstable Engine Operation Occurs Intermittently

If the fuel pump filter is clogged, unstable engine operation will occur intermittently while riding.

Even if this symptom occurs, you can continue to ride your vehicle.

If unstable engine operation occurs even if sufficient fuel is available, have your vehicle inspected by your dealer as soon as possible.

Information

Service Diagnostic Recorders	P. 194
Keys.....	P. 194
Instruments, Controls, & Other Features...	P. 197
Caring for Your Vehicle.....	P. 199
Storing Your Vehicle.....	P. 203
Transporting Your Vehicle	P. 203
You & the Environment	P. 204
Serial Numbers	P. 205
Fuels Containing Alcohol	P. 206
Catalytic Converter	P. 207

Service Diagnostic Recorders

Your vehicle is equipped with service-related devices that record information about powertrain performance and riding conditions. The data can be used to help technicians diagnose, repair and maintain the vehicle. This data may not be accessed by anyone else except as legally required or with the permission of the vehicle owner.

However, this data may be accessed by Honda, its authorised dealers and authorised repairers, employees, representatives, and contractors only for the purpose of the technical diagnosis, research, and development of the vehicle.

Keys

Emergency Key

The emergency key is used for an emergency.

- To unlock the seat. ➤ P. 183

Do not store the emergency key in any compartment.

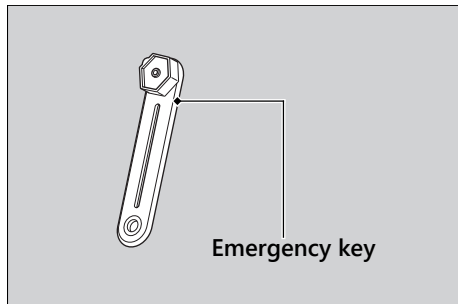

Honda SMART Key

Carrying the Honda SMART Key allows you to perform the following operations:

- Locking or unlocking the ignition switch
- Releasing the seat lock
- Opening the fuel lid
- Locking or unlocking the steering

The ID number of the Honda SMART Key is on the ID tag. You can also unlock the ignition switch by inputting the ID number.

Always carry both the emergency key and ID tag, but separate from the Honda SMART Key, to avoid losing all of them at the same time.

Also store a copy of your ID number in a safe place other than your vehicle.

The Honda SMART Key contains electronic circuits. If the circuits are damaged, the Honda SMART Key will not allow you to perform any operations.

- Do not drop the Honda SMART Key or set heavy objects on them.
- Protect the Honda SMART Key from direct sunlight, high temperature, and high humidity.
- Do not scratch or puncture.
- Do not store near any magnetized products such as a magnetized key chain.
- Always keep the Honda SMART Key away from electric appliances such as a TV, radio, PC or low-frequency massage device.
- Keep the Honda SMART Key away from liquids. If it gets wet, dry it immediately with a soft cloth.
- Keep the Honda SMART Key away from the vehicle while washing the vehicle.
- Do not burn.
- Do not wash in an ultrasonic cleaner.

Keys

- If fuel, wax, or grease adhere to the Honda SMART Key, wipe it off immediately to avoid cracking or warping.
- Do not disassemble the Honda SMART Key other than when changing a battery. Only the cover of the Honda SMART Key can be disassembled. Do not disassemble other parts.
- Do not lose your Honda SMART Key. If you lose it, you will need to register a new Honda SMART Key. See your dealer with your emergency key and ID tag for registration.

The battery in the Honda SMART Key system normally lasts about 2 years.

Do not keep mobile phones or other radio transmitting devices in any compartment. The radio frequency from the devices will interrupt the Honda SMART Key system.

To get an additional Honda SMART Key, take the Honda SMART Key and the vehicle to your dealer.

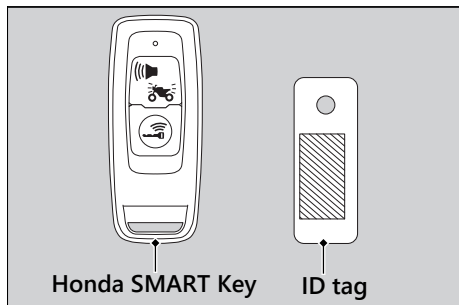

Instruments, Controls, & Other Features

Ignition Switch

Leaving the ignition switch in the **I** (On) position with the engine stopped will drain the battery.

Do not turn the ignition switch while riding.

Odometer

The display remains at 999,999 when the odometer exceeds 999,999.

Tripmeter

Each tripmeter resets to 0.0 when the trip mileage exceeds 9,999.9.

Average fuel mileage A/B and elapsed time A/B are reset at the same time.

Document Bag

The owner's manual, registration, and insurance information can be stored in the plastic document bag located underside of the seat.

Automatic Brightness Control

III MA, VII MA type

The backlight brightness and background of the meter will be controlled automatically when "AUTO" is selected on the BRIGHTNESS or the BACKGROUND setting. ➤ P. 46 ➤ P. 47
Ambient brightness is detected by the photosensor.

Do not damage or cover the photosensor.
Otherwise, the automatic brightness control may not work properly.

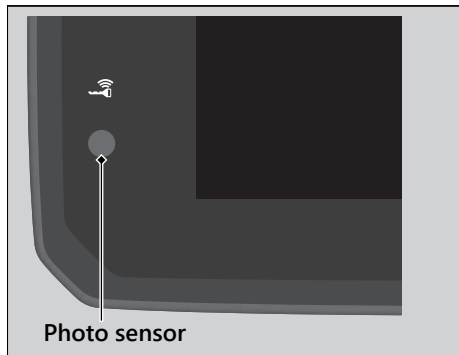

Caring for Your Vehicle

Frequent cleaning and polishing is important to ensure the life of your Honda. A clean vehicle makes it easier to spot potential problems. In particular, seawater and salts used to prevent ice on roads promote the formation of corrosion. Also, mud and dust may accelerate front suspension wear and cause oil leaks. Always wash your vehicle thoroughly after riding on coastal, treated, muddy, or dusty roads.

Washing

Allow the engine, muffler, brakes, and other high-temperature parts to cool before washing.

1. Rinse your vehicle thoroughly using a low pressure garden hose to remove loose dirt.
2. If necessary, use a sponge or a soft towel with mild cleaner to remove road grime.
 - ▶ Clean the windscreen, headlight lens, panels, and other plastic components with extra care to avoid scratching them.

Avoid directing water into the air cleaner, muffler, and electrical parts.

3. Thoroughly rinse your vehicle with plenty of clean water and dry with a soft, clean cloth.
4. After the vehicle dries, lubricate any moving parts.
 - ▶ Make sure that no lubricant spills onto the brakes or tyres. Brake discs, pads, drums, or shoes contaminated with oil will suffer greatly reduced braking effectiveness and can lead to a crash.
5. Apply a coat of wax to prevent corrosion.
 - ▶ Avoid products that contain harsh detergents or chemical solvents. These can damage the metal, paint, and plastic on your vehicle. Keep the wax clear of the tyres and brakes.
 - ▶ If your vehicle has any mat painted parts, do not apply a coat of wax to the mat painted surface.

Washing Precautions

Follow these guidelines when washing:

- Do not use high-pressure washers:
 - ▶ High-pressure water cleaners can damage moving parts and electrical parts, rendering them inoperable.
 - ▶ Water in the air intake can be drawn into the throttle body and/or enter the air cleaner.
 - Do not direct water at the muffler:
 - ▶ Water in the muffler can prevent starting and causes rust in the muffler.
 - Dry the brakes:
 - ▶ Water adversely affects braking effectiveness. After washing, apply the brakes intermittently at low speed to help dry them.
 - Do not direct water under the seat:
 - ▶ Water in the under seat compartment can damage your documents and other belongings.
-
- Do not direct water at the air cleaner:
 - ▶ Water in the air cleaner can prevent the engine from starting.
 - Do not direct water near the headlight:
 - ▶ The headlight's inside lens may fog temporarily after washing or while riding in the rain. This does not impact the headlight function. However, if you see a large amount of water or ice accumulated inside the lens(es), have your vehicle inspected by your dealer.
 - Do not use wax or polishing compounds on matte painted surfaces:
 - ▶ Use a soft cloth or sponge, plenty of water, and a mild detergent to clean mat painted surfaces. Dry with a soft clean cloth.

Aluminium Components

Aluminium will corrode from contact with dirt, mud, or road salt. Clean aluminium parts regularly and follow these guidelines to avoid scratches:

- Do not use stiff brushes, steel wool, or cleaners containing abrasives.
- Avoid riding over or scraping against curbs.

Panels

Follow these guidelines to prevent scratches and blemishes:

- Wash gently using a soft sponge and plenty of water.
- To remove stubborn stains, use diluted detergent and rinse thoroughly with plenty of water.
- Avoid getting petrol, brake fluid, or detergents on the instruments, panels, or headlight.

Windscreen

Using plenty of water, clean the windscreen with a soft cloth or sponge. (Avoid using detergents or any kind of chemical cleaner on the windscreen.) Dry with a soft, clean cloth.

NOTICE

To avoid possible scratching or other damage, use only water and a soft cloth or sponge to clean the windscreen.

For a dirtier windscreen, use a diluted neutral detergent with a sponge and plenty of water. Make sure to wash off all the detergent. (Detergent residue may cause windscreen cracks.)

Replace the windscreen if scratches cannot be removed and they obstruct clear vision.

Take care to keep battery electrolyte, brake fluid, or other chemical solvents off the windscreen and screen garnish. They will damage the plastic.

Exhaust Pipe and Muffler

If the exhaust pipe and muffler are painted, do not use a commercially available abrasive kitchen cleaning compound. Use a neutral detergent to clean the painted surface on the exhaust pipe and muffler. If you are not sure if your exhaust pipe and muffler are painted, contact your dealer.

Storing Your Vehicle

If you store your vehicle outdoors, you should consider using a full-body cover.

If you won't be riding for an extended period, follow these guidelines:

- Wash your vehicle and wax all painted surfaces (except mat painted surfaces). Coat chrome pieces with rust-inhibiting oil.
- Place your vehicle on its centre stand and position a block so that both tyres are off the ground.
- After rain, remove the body cover and allow the vehicle to dry.
- Remove the battery (➔ P. 152) to prevent discharge. Fully charge the battery and then place it in a shaded, well-ventilated area.
 - ▶ If you leave the battery in place, disconnect the negative ⊖ terminal to prevent discharge.

After removing your vehicle from storage, inspect all maintenance items required by the Maintenance Schedule.

Transporting Your Vehicle

If your vehicle needs to be transported, it should be carried on a motorcycle trailer or a flatbed truck or trailer that has a loading ramp or lifting platform and motorcycle tie-down straps. Never try to tow your vehicle with a wheel or wheels on the ground.

NOTICE

Towing your vehicle with a wheel or wheels on the ground can cause serious damage to the transmission.

You & the Environment

Owning and riding a vehicle can be enjoyable, but you must do your part to protect the environment.

Choose Sensible Cleaners

Use a biodegradable detergent when you wash your vehicle. Avoid aerosol spray cleaners that contain chlorofluorocarbons (CFCs) which damage the atmosphere's protective ozone layer.

Recycle Wastes

Put oil and other toxic wastes in approved containers and take them to a recycling centre. Call your local or state office of public works or environmental services to find a recycling centre in your area and to get instructions on how to dispose of non-recyclable wastes. Do not place used engine oil in the trash or pour it down a drain or on the ground. Used oil, petrol, coolant, and cleaning solvents contain poisons that can hurt refuse workers and contaminate drinking water, lakes, rivers, and oceans.

Serial Numbers

The frame and engine serial numbers uniquely identify your vehicle and are required in order to register your vehicle. They may also be required when ordering replacement parts. To check the frame number, open the seat.

➤ P. 133

You should record these numbers and keep them in a safe place.

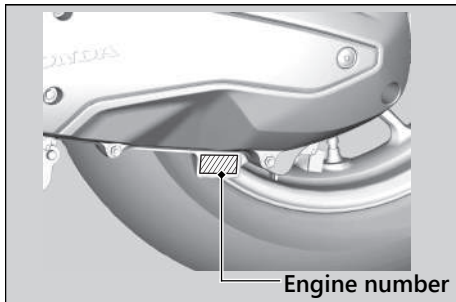
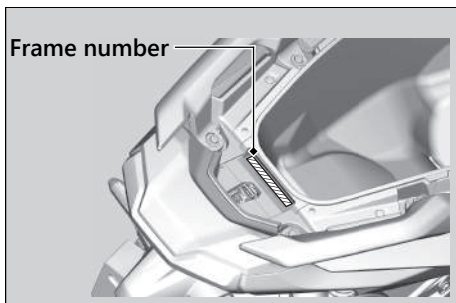

Fuels Containing Alcohol

Some conventional fuels blended with alcohol are available in some locales to help reduce emissions to meet clean air standards. If you plan to use blended fuel, check that it is unleaded and meets the minimum octane rating requirement.

The following fuel blends can be used in your vehicle:

- Ethanol (ethyl alcohol) up to 10% by volume.
 - ▶ Petrol containing ethanol may be marketed under the name Gasohol.

The use of petrol containing more than 10% ethanol may:

- Damage the painting of the fuel tank.
- Damage the rubber tubes of the fuel line.
- Cause corrosion of the fuel tank.
- Cause poor drivability.

NOTICE

Use of blended fuels containing higher than approved percentages can damage metal, rubber, plastic parts of your fuel system.

If you notice any undesirable operating symptoms or performance problems, try a different brand of petrol.

Catalytic Converter

This vehicle is equipped with two three-way catalytic converters. Each catalytic converter contains precious metals that serve as catalysts in high temperature chemical reactions that convert hydrocarbons (HC), carbon monoxide (CO), and oxides of nitrogen (NO_x) in the exhaust gases into safe compounds.

A defective catalytic converter contributes to air pollution and can impair your engine's performance. A replacement unit must be an original Honda part or equivalent.

Follow these guidelines to protect your vehicle's catalytic converters:

- Always use unleaded petrol. Leaded petrol will damage the catalytic converters.
- Keep the engine in good running condition.
- Have your vehicle serviced if your engine is misfiring, backfiring, stalling, or otherwise not running properly, stop riding and turn off the engine.

Specifications

■ Main Components

Overall length	1,950 mm (76.8 in)	
Overall width	763 mm (30.0 in)	
Overall height	Windscreen position	
	High	1,270 mm (50.0 in)
	Low	1,196 mm (47.1 in)
Wheelbase	1,324 mm (52.1 in)	
Minimum ground clearance	165 mm (6.5 in)	
Caster angle	26° 30'	
Trail	85 mm (3.3 in)	
Curb weight	133 kg (293 lb)	
Maximum weight capacity *1	180 kg (397 lb)	
Maximum luggage weight *2	Centre compartment	10 kg (22 lb)
	Front box	1 kg (2.2 lb)
Passenger capacity	Rider and 1 passenger	
Minimum turning radius	2.00 m (6.6 ft)	

*1 : Including rider, passenger, all luggage, and accessories.

*2 : Includes the weight of the luggage and added accessories.

Displacement	156.93 cm ³ (9.573 cu-in)
Bore x stroke	60.000 x 55.502 mm (2.3622 x 2.1851 in)
Compression ratio	12.0:1
Fuel	Unleaded petrol Recommended: 91 RON or higher
Fuel containing alcohol	ETHANOL up to 10 % by volume
Tank capacity	8.1 L (2.14 US gal, 1.78 Imp gal)
Battery	YTZ6V 12 V-5 Ah (10 HR)
Primary reduction	V-Matic (2.52:1 to 0.81:1)
Final reduction	9.589

■ **Service Data**

Tyre size	Front	110/80-14M/C 53P
	Rear	130/70-13M/C 57P
Tyre type		Bias-ply, tubeless
Recommended Tyres	Front	SRI FT297
	Rear	SRI FT297
Tyre air pressure (Drivers only)	Front	200 kPa (2.00 kgf/cm ² , 29 psi)
	Rear	225 kPa (2.25 kgf/cm ² , 33 psi)
Tyre air pressure (Driver and passenger)	Front	200 kPa (2.00 kgf/cm ² , 29 psi)
	Rear	225 kPa (2.25 kgf/cm ² , 33 psi)
Minimum tread depth	Front	1.5 mm (0.06 in)
	Rear	2.0 mm (0.08 in)
Spark plug		LMAR8L-9 (NGK)
Spark plug gap		0.8 - 0.9 mm (0.03 - 0.04 in)
Idle speed		1,700 ± 100 rpm
Recommended engine oil		Honda 4-stroke motorcycle oil API Service Classification SJ or higher, excluding oils marked as "Energy Conserving" or "Resource Conserving," SAE 10W-30, JASO T 903 standard MB

Engine oil capacity	After draining	0.75 L (0.79 US qt, 0.66 Imp qt)
	After disassembly	0.9 L (1.0 US qt, 0.8 Imp qt)
Final drive oil capacity	After draining & cleaning strainer screen	0.85 L (0.90 US qt, 0.75 Imp qt)
	After draining	0.12 L (0.13 US qt, 0.11 Imp qt)
Recommended brake fluid	After disassembly	0.13 L (0.14 US qt, 0.11 Imp qt)
		Honda DOT 3 or DOT 4 Brake Fluid
Cooling system capacity		0.50 L (0.53 US qt, 0.44 Imp qt)
Recommended coolant		HONDA PRE-MIX COOLANT

Specifications

■ Bulbs

Headlight/Position light	LED
Brakelight/Taillight	LED
Front turn signal	LED
Rear turn signal	LED
License plate light	LED

■ Fuses

Main fuse	30 A
Other fuse	15 A, 10 A, 5 A

